

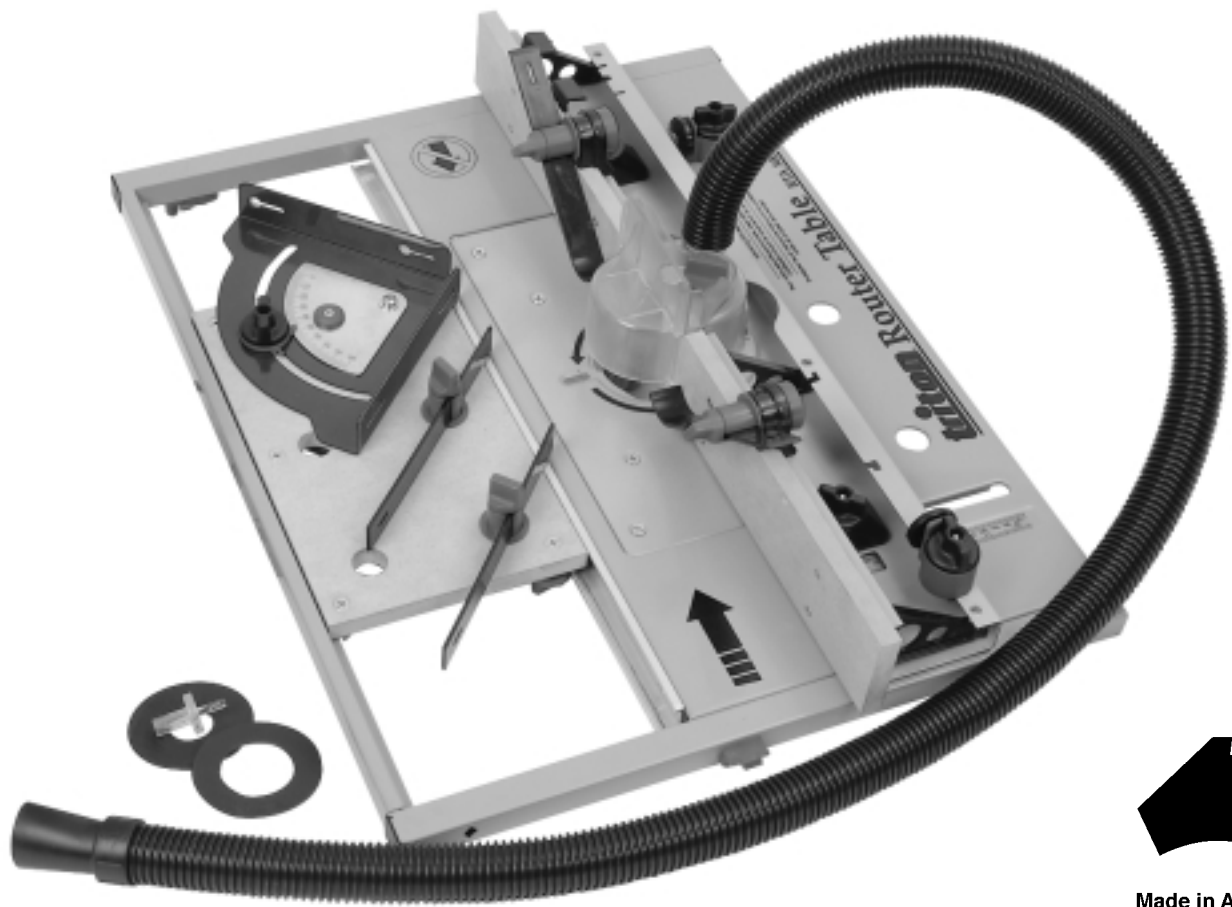

Router Table RTA300



Assembly & Operating Instructions

Thank you for purchasing the Triton Router Table. Please take a few minutes to read these instructions before beginning to assemble and use the product. If you follow our recommended set-up and operation, and fit good quality cutters you will obtain excellent results.

This table is designed to suit all Triton MK3 & Series 2000 Workcentres and Triton Router Stands.

CONTENTS

	Page		Page
COMPONENTS LIST	3	Trenching	8
FITTING THE TABLE	2-3	Planing with a Router	9
ASSEMBLY	3-6	Edge Moulding	11
SAFETY	6	End Grain Work	11
USING A ROUTER - GETTING THE BEST CUTS	6	Using a Template Guide	11
OPERATION	6-12	Morticing	12
Edge Rebating	7	RECOMMENDATIONS FOR ROUTER SELECTION	12

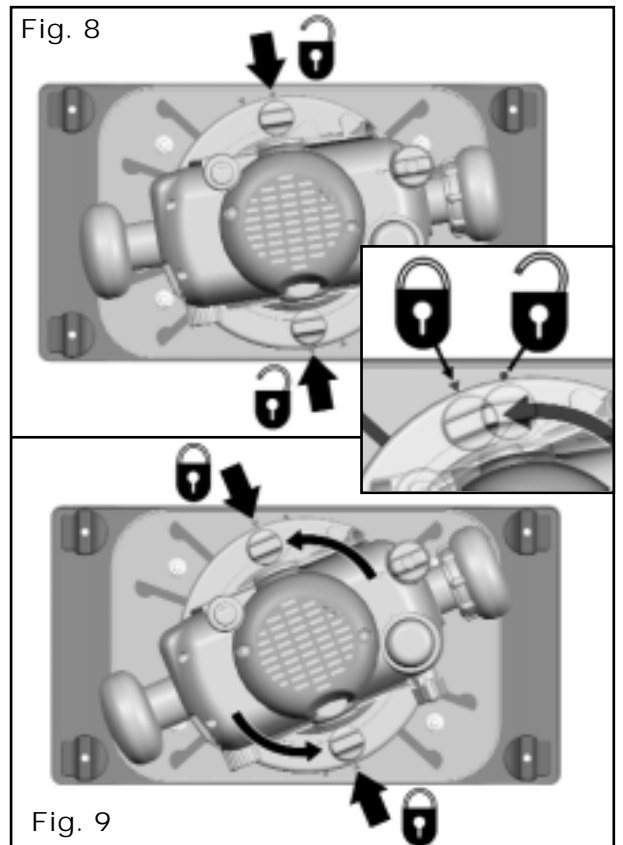
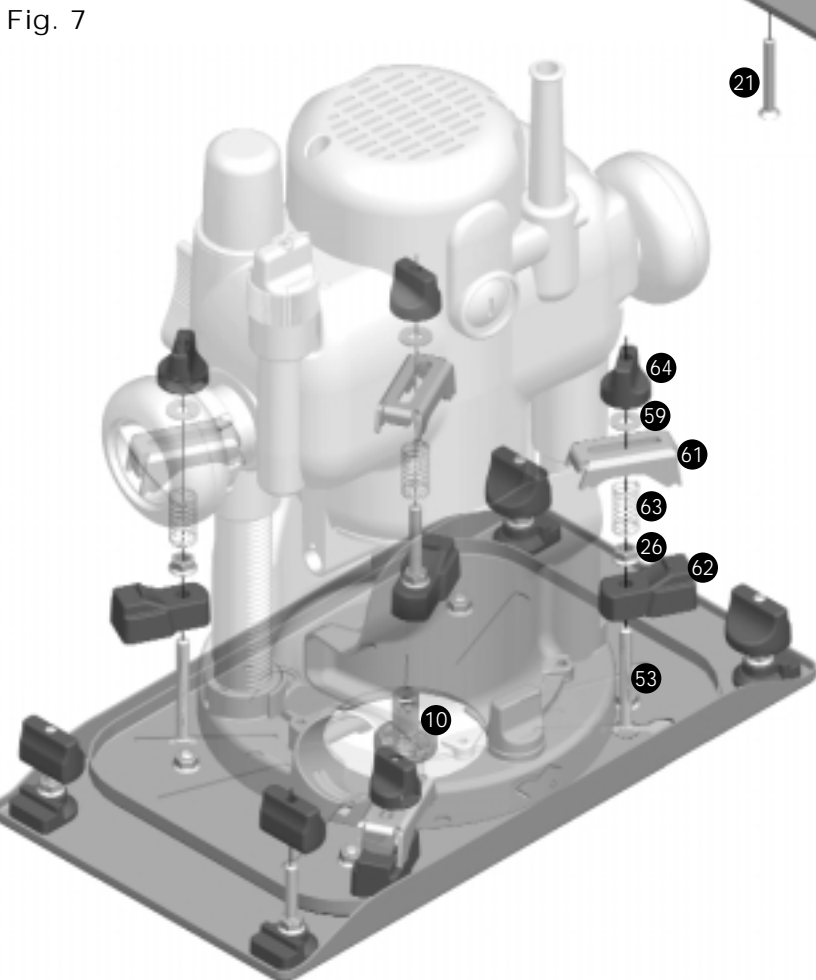
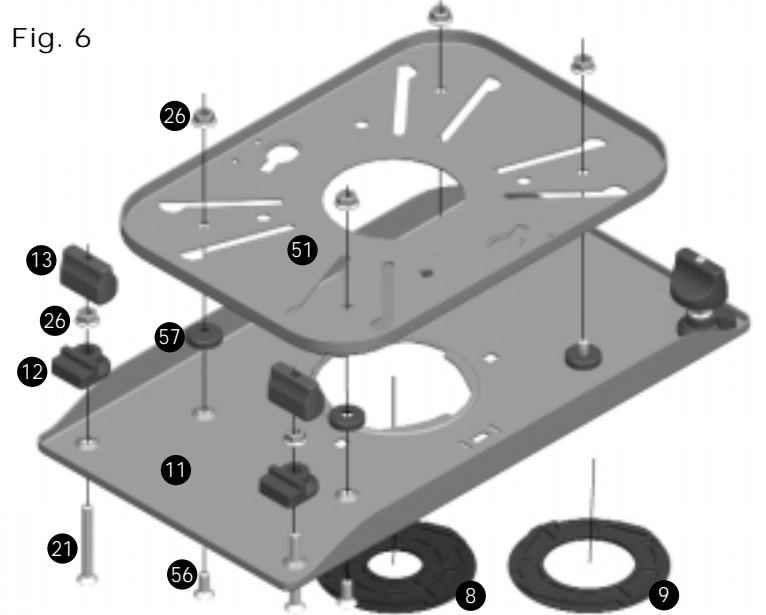
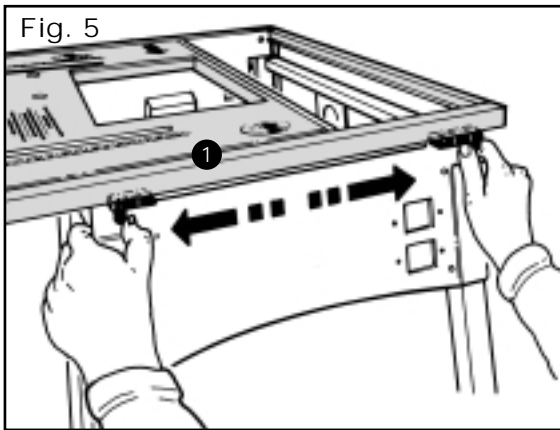
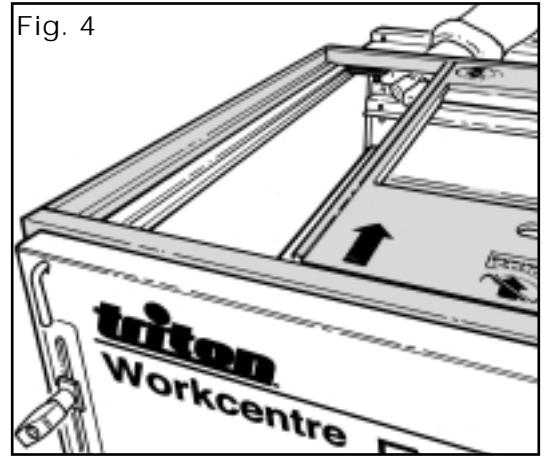
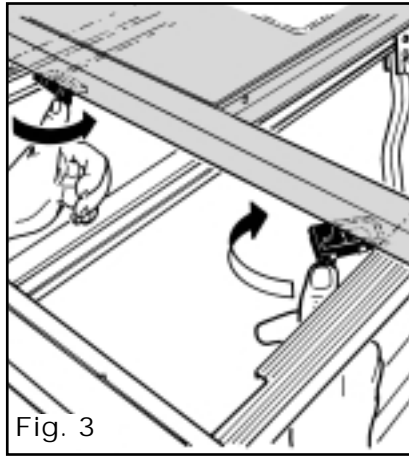
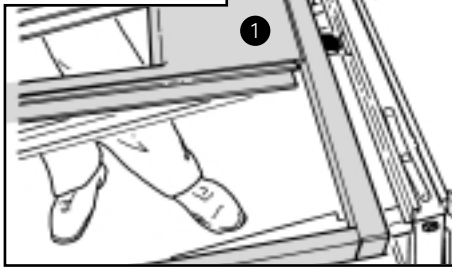
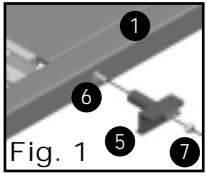

COMPONENTS LIST

- 1 Router table x 1
- 2 Vacuum hose x 1
- 3 Protractor x 1

Fastener bag 1 contents

- 4 Tapered hose adaptor x 1
- 5 Series 2000 Workcentre Locking Hook x 1
- 6 M4 x 35 Countersunk Screw x 1
- 7 M4 Hex Nut x 1
- 8 Small Insert Ring x 1
- 9 Large Insert Ring x 1
- 10 Alignment Tool x 1

Router Plate Components

- 11 Router plate x 1
- 51 Sub plate x 1

Fastener bag 2 (Router plate) contents:

- 12 Plate Clamp Base x 4
- 13 Plate Clamp Knob x 4
- 21 M6 x 45 Countersunk Screw x 4
- 26 M6 Flange Nut x 12
- 53 M6 x 60 Coach Bolt x 4

- 56 M6 x 16 Countersunk Screw x 4
- 57 Plate Spacer x 4
- 59 Washer x 4
- 61 Clamp x 4
- 62 Clamp Base x 4
- 63 Clamp Spring x 4
- 64 Clamp Knob x 4

Sliding Table Insert Components

- 27 Sliding Table Insert x 1

Fastener Bag 3 (Sliding Table) contents:

- 28 Inner Bearing x 2
- 29 Inner Clamp Knob x 2
- 30 Outer Bearing x 2
- 31 Hold-down x 1
- 21 M6 x 45 Countersunk Screw x 2
- 41 M6 x 20 Countersunk Screw x 3
- 26 M6 Flange Nut x 2
- 32 M6 Hex Nut x 3

Fence Components

- 33 Fence x 1
- 34 MDF Fence Face x 2
- 35 Rear Guard x 1
- 36 Front Guard x 1

Fastener bag 4 (Fence) contents:

- 37 Fence Bracket x 2
- 38 M4 Nyloc Nut x 10
- 39 M4 x 25 Countersunk Screw x 2
- 43 1.5 mm Shim x 2
- 44 1.0 mm Shim x 2
- 45 Micro Adjuster x 2
- 65 M4 x 45 Countersunk Screw x 8
- 66 Fence Springs x 8
- 67 Fence Spring Base x 4
- 68 Fence Spring Plate x 4

Pressure Finger Components (in bag)

- 46 Straight Finger x 2
- 47 Bent Finger x 2
- 48 Spacer x 2
- 49 Plastic Washer x 4
- 50 Finger Post x 4

FITTING THE TABLE

Assembly of this product is best done with the table fitted to your Workcentre or Router Stand.

Fitting to a Triton Series 2000 Workcentre
Fit the Series 2000 Workcentre Locking Hook (5) to the front tube of the Table (1) using the M4 x 35 Countersunk Screw (6) and M4 Hex Nut (7). **Fig. 1**

Locate the hook into the slot in the front end panel of the Workcentre and lower the rear of the table onto the bearing channels. **Fig. 2**

The Router Table is packed with the rear locking catches positioned to fit the Workcentre (domed posts on the inside and catches slid toward one another). Swing the post ends of the latches out toward the rear end panel, and allow the rear of the table to sit down flat on the bearing channels. Secure the rear down by swinging the catches forward into the bearing channels. **Fig. 3**

Fitting to a Triton MK3 Workcentre
Place the Table (1) behind the front end panel of the Workcentre and rest it on the bearing channels. Align the keyholes in the front end panel of the Workcentre with those in the front tube of the Router Table and use the MK3 table locking pins to lock the table in position. **Fig. 4**

Secure the rear of the table down as described above in the last paragraph of "Fitting to a Triton Series 2000 Workcentre". **Fig. 3**

Fitting to a Triton Router Stand
Fit the Table (1) over the front end panel of the Router Stand with the conical pins locating through the holes on the inside face of the front tube of the table.

The rear locking latches must be reversed from their packed position by swinging the domed post ends of the catches outward and sliding the catches inwards, toward one another. Secure the rear of the table down by lowering it onto the tabs in the rear end panel then sliding the catches outward to engage into the forms on the panel. **Fig. 5**

New Model Router Stand - RSA 300: There are four hanging hooks supplied with the new model Triton Router Stand (RSA 300) which snap onto the lower tubes of the stand. The two wide hooks are used for storage of the Router Table fence - it hangs via the scale pointer holes.

These should be fitted to the right hand side of the stand (when viewed from the switchbox end). The two narrow hooks are for storage of the pressure finger assemblies which hang via the finger slots. These should be fitted on the left side. This model stand also has a hole in the rear panel for storage of the protractor (3). For a tight fit bend the tab in the top of the hole downward slightly.

ASSEMBLING THE ROUTER PLATE

Fit the Clamp Bases (12) to the corners of the underside of the Router Plate (11) with the M6 x 45 Countersunk Screws (21) and M6 Flange Nuts (26). Do not tighten yet. **Fig. 6**

Fit the sub plate to the router plate using the M6 x 16 Countersunk Screws (56), Plate Spacers (57) and M6 Flange Nuts (26). Tighten firmly.

Fit the Small Insert Ring (8) into the router plate. It twist locks into position.

Sit the router plate into the central cut-out in the table (clamp bases facing down) with the depressed slot in the plate on the left (when viewed from the switchbox end). Slide the clamp bases outward until they locate against the square tube supports, ensuring there is no movement in the plate, then tighten firmly in position.

Screw the Plate Clamp Knobs (13) onto the screws until they hold the router plate firmly into the table (they cut their own thread).

In use: The clamps have cut-away edges. When all four cut-aways are facing outward the plate can be removed. Turn the knobs clockwise about half a turn to tighten it back down. Locate the plate upside down in the table to hold it still while fitting the router.

FITTING YOUR ROUTER TO THE SUB PLATE

Triton 1/2" Precision Routers: The sub plate has been designed for direct mounting of the Triton Router.

Loosen the two Mounting Knobs on the Router until they are approximately 10mm ($\frac{3}{8}$ ") above the base of the router. Locate the router onto the sub plate with the chuck plunged through the small insert ring. Align the mounting knobs with the small round holes **Fig. 8**. Push down on the mounting knobs until the bolt heads locate into the keyholes and rotate the router anti-clockwise until the knobs align with the small triangle holes **Fig. 9**. Tighten the mounting knobs firmly.

Fig. 10

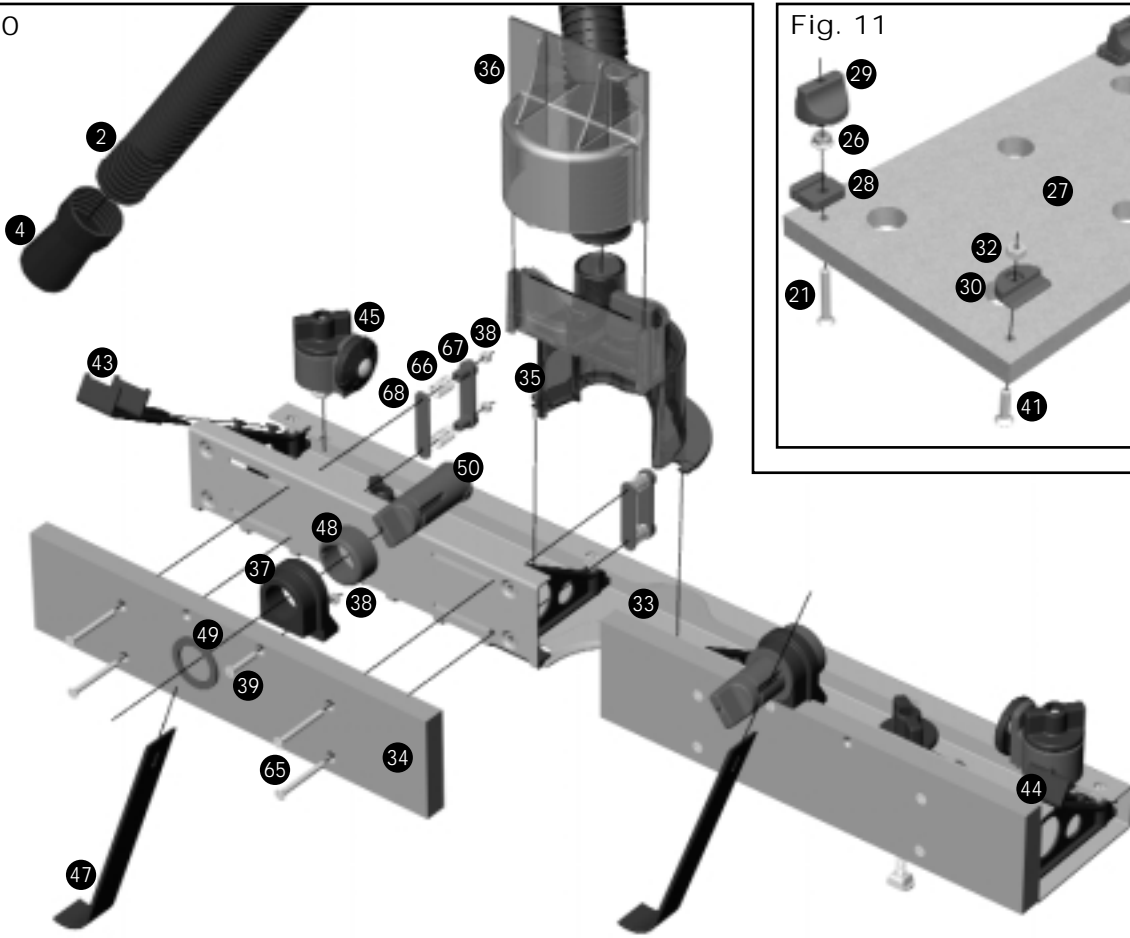

Fig. 11

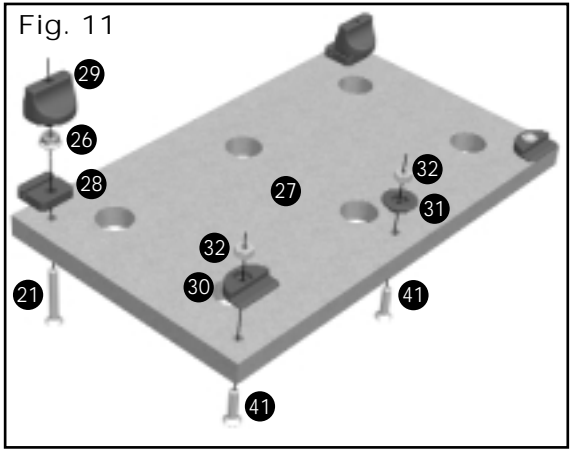

Fig. 12

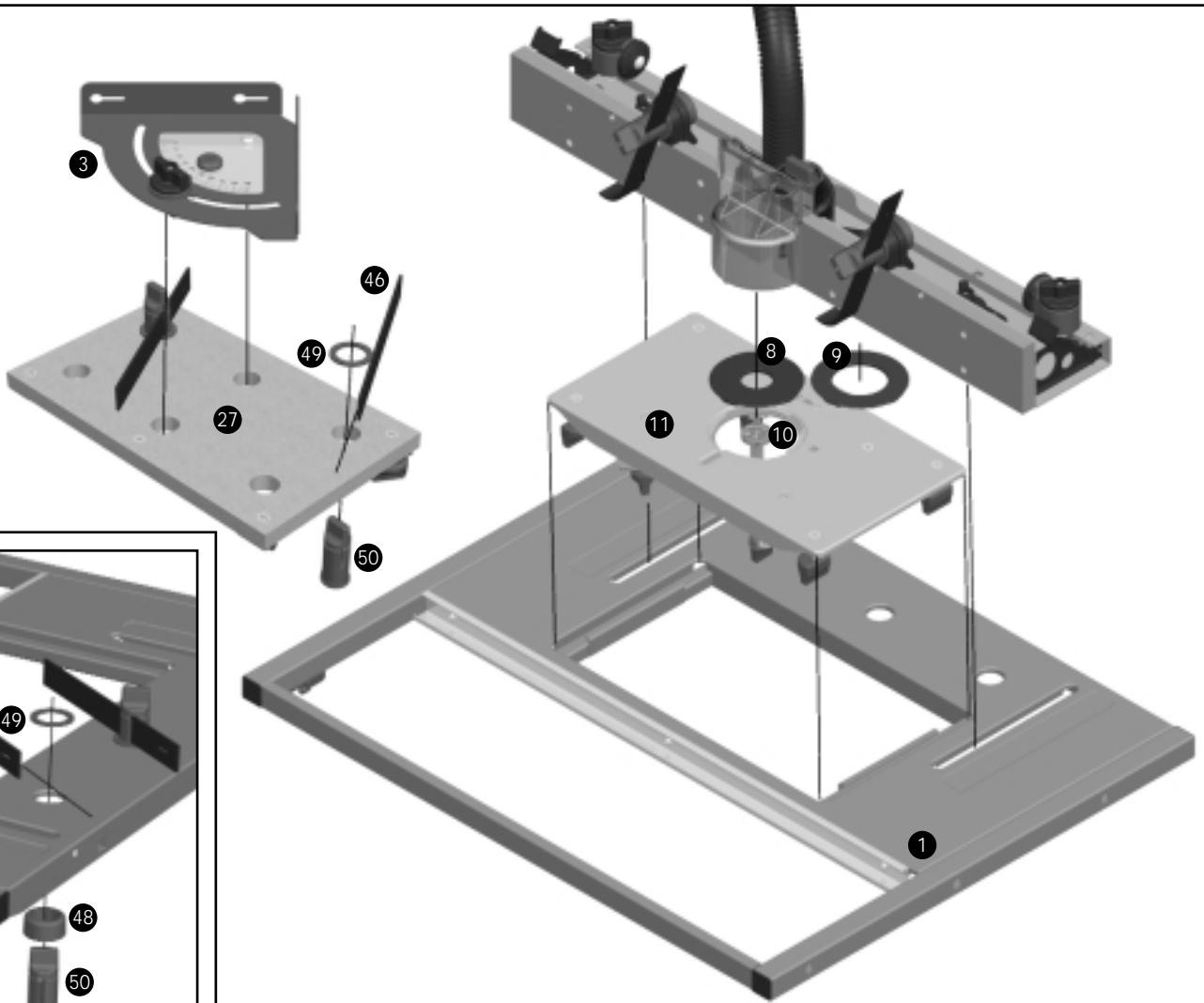
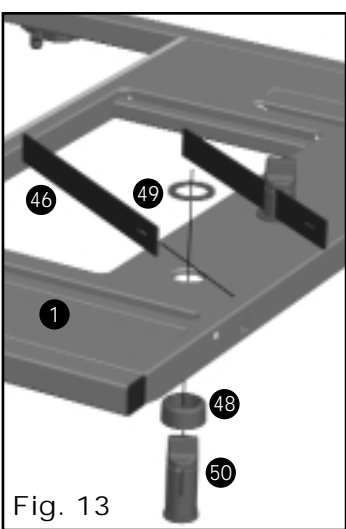

Fig. 13



Other Routers: Lock your router at full depth and fit the Router Alignment Tool (10) into the collet. Place the router onto the Sub Plate (51) with the alignment tool fitting snugly through the small insert ring. **Note:** Most large routers fit best with their handles angled diagonally across the plate. **Fig. 7**

Determine the four most suitable clamp slots - ensuring you do not obstruct any of the router controls. If 4 suitable clamping positions cannot be achieved, 3 well spaced clamps are acceptable. Alternatively, remove the obstruction (eg. turret) from the router, or attempt to straddle the clamp over it. Locate the heads of the M6 x 50 Coach Bolts (53) into the openings of these slots and loosely assemble the Clamp Bases (62) onto them using M6 Flange Nuts (26). Remove the router.

Slide the clamp bases up against the base of the router and tighten the flange nuts with a 10mm spanner.

Fit the Clamp Springs (63), Clamps (61) then Washers (59) over the bolts and loosely fit the Clamp Knobs (64). Determine which end of the clamps best suits your router base then slide them over a free position on the base. Tighten the clamp knobs firmly.

Removing the router: Loosen the clamp knobs and slide back the clamps to dis-engage them from the router base.

Porter Cable Routers: Four holes are provided to suit direct screw mounting of Porter Cable routers to the sub plate via their base mounting screws, if preferred.

ASSEMBLING THE SLIDING TABLE INSERT

Tighten the Outer Bearings (30) and Hold-down (31) onto the Sliding Table Insert (27) using the M6 x 20 Screws (41) and M6 Hex Nuts (32). Fit the Inner Bearings (28) to the insert using the M6 x 45 Screws (21) and M6 Flange Nuts (26). Do not yet tighten. **Fig. 11**

Locate the insert into the tracks in the table by hooking the hold-down under the outer (orange) track first. The slots on the inner bearings should locate onto the flange on the aluminium inner track. Now firmly tighten the inner bearing screws and check that the insert slides smoothly. If there is any movement between the aluminium inner track and the inner bearings, loosen the screws, twist the bearing slightly and re-tighten.

Screw the Inner Clamp Knobs (29) onto the inner bearing screws, they cut their own thread. **Fig. 11.**

In use: The clamps have cut-away edges and have three modes of use. When the cut-away edges are facing the inner track the insert is free to slide and can be removed. When the clamps are tensioned firmly with the cut-away edges facing inwards, the insert is locked from sliding. By backing off the clamps one complete turn the insert is free to slide but cannot be removed.

Check that the insert is level or is slightly above the table surface and if necessary loosen the three screws securing the aluminium inner track and make any required adjustment before re-tightening.

ASSEMBLING THE FENCE

Fit the Rear Guard (35) to the Fence (33) by inserting the front tabs first. Slide the red locking tab up then lower the rear of the guard while depressing the rear catch. When the catch snaps into place slide the locking tab down to lock the guard in position.

Attach the MDF Fence Faces (34) using the M4 x 45 Countersunk Screws (65) via the long slots in the fence. Position them with the two extra holes at the top. Fit the Fence Spring Plates (68) (with their flat faces against the

fence), Fence Springs (66) and Fence Spring Bases (67) onto the bolts at the rear of the fence and tighten into position using M4 Nyloc Nuts (38). Tension the nuts so that the MDF holds securely against the fence.

In use: The MDF faces should always be positioned as close to the cutter as possible. Position them by sliding forward or backward. Ensure they are tensioned firm enough to resist unwanted movement. For very heavy or difficult cuts lock the faces by fully tightening the screws.

Fit the Fence Brackets (37) to the inner holes of the MDF Fence Faces using the M4 x 25 Countersunk Screws (39) and M4 Nyloc Nuts (38). **Fig. 10**

Insert the Front Guard (36) into the tracks on the rear guard. Some initial force may be necessary. Loosen the knob and slide the guard guide forward until the front guard can be fully lowered and the guard slides against the MDF, then tighten.

Loosen the round knobs and fit the fence to the table via the T-bolts through the table slots. The T-bolts are designed to pass through the table slots and then be turned through 90°, locking the fence to the table when the knobs are tightened.

Check Fence Squareness: The fence is held square by four adjustable braces. Use a set square against the face of the fence to check it is square to the table. If necessary loosen the horizontal locking screws through the rear flange of the fence and adjust the vertical jacking screws in the braces until the fence is square, then re-tighten the locking screws. Adjust the two front braces together then the two rear braces together. **Fig. 14**

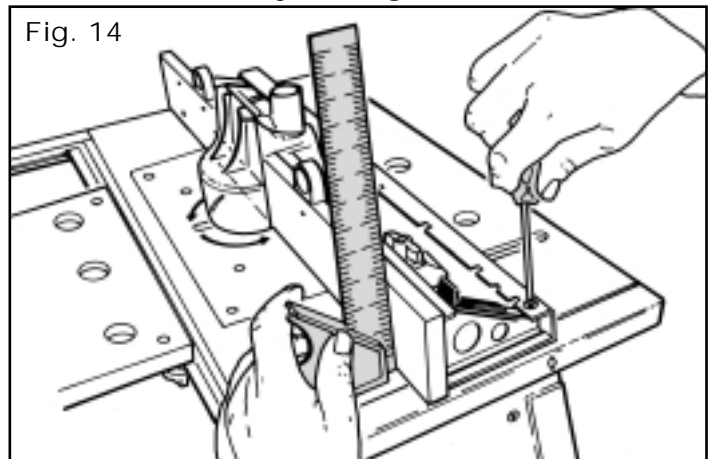

Storage hints: When not in use, the front guard can be stored in the notches at the rear of the fence.

The **Micro Adjusters** (45) should be fitted in their storage position when not in use, as shown in **Fig. 10**. When in use they relocate to the slots behind the fence, as shown in **Fig. 18**.

The **Planing Shims** (43 & 44) slide (in pairs) over pins on the fence braces when not in use, as shown in **Fig. 10**. When in use they are fitted behind the MDF fence faces. **Figs. 25 & 26**. If necessary loosen off the fence springs to accommodate fitting of the shims, then re-tighten to the desired tension.

ASSEMBLING THE PRESSURE FINGERS

Insert two Finger Posts (50) with Spacers (48) through the holes in the fence brackets and fit the Plastic Washers (49). Insert the Bent Pressure Fingers (47) through the slots and tighten the knobs on top of the finger posts to tension them into position.

Insert the remaining two finger posts through the preferred holes in the sliding insert then fit the washers and Straight Fingers (46) before tightening. **Fig. 12**

The finger posts with spacers can also be fitted directly to the holes in the table for operations such as “Planing to Width”. The finger post spacers should be reversed when fitting to the table. **Fig. 13.**

The bent and straight pressure fingers are interchangeable depending on the operation you are performing.

ADJUSTING THE PROTRACTOR

Fit the Protractor (3) to the preferred holes in the MDF slider and tighten the small knobs on the locating bosses until they are a snug fit. If the knobs are too tight to turn by hand a small spanner can be used. With the knobs fully tightened the protractor cannot be removed. **Fig. 12**

Checking the protractor scale: Loosen the adjustment knob and line the edge of the protractor up with the aluminium inner track. Check that the scale pointer is at 90°. If necessary, loosen the central clamping screw and adjust the position of the metal scale plate until it reads 90°. **Fig. 15**

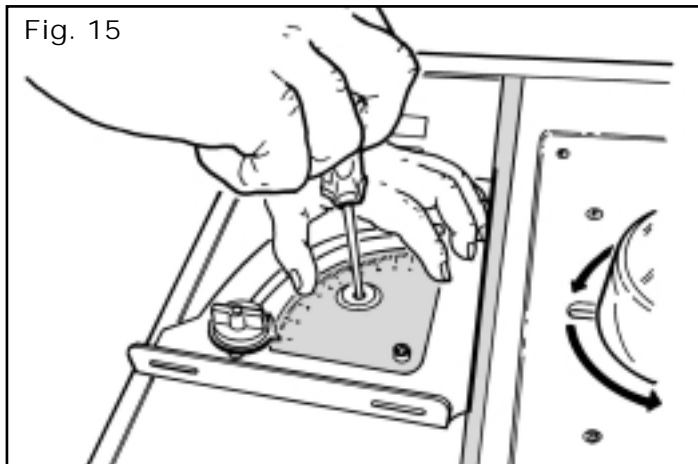

In use: The protractor can fit in any of the three pairs of holes in the MDF slider. In most cases the protractor will be used following the workpiece. An extended wooden face should be fitted to the protractor to support the workpiece close to the cutter. By also trimming the wooden face as it passes the cutter, tear-out in the workpiece will be prevented. The holes for mounting the wooden face are slotted to allow re-trimming.

SAFETY

There are a number of important rules that must be followed to ensure safe operation of your equipment:

- Always feed the workpiece against the direction of rotation arrows (printed around the central hole). You must always feed from the front panel (switchbox end) of the Workcentre or Router Stand, with the workpiece to the left of the cutter.
- Never trail your fingers behind the workpiece.
- Always use the fence if using a cutter without a bearing or pilot.
- For free-hand work use only bearing or pilot guided cutters.
- Use the safety guard whenever possible, and keep it correctly adjusted.
- Always disconnect your router from power whenever changing or adjusting cutters.
- Always check that the cutter is clear of the MDF fence faces, the insert ring, the safety guard and the workpiece before starting the router.
- Always wear eye protection whenever operating power tools. Use of a dust mask and ear muffs is also recommended.

- Do not wear loose clothing or jewellery when operating power tools. Tie back long hair.
- Ensure all fasteners are regularly checked for tightness as router vibration can loosen them.
- Remove all loose objects from the table before operating to prevent them from vibrating into the cutter.
- Always disconnect power when work is completed for the day, or when leaving the unit unattended.

USING A ROUTER - GETTING THE BEST CUTS

The quality of your cuts when using a router depends on a number of important factors:

The Feed Rate

Don't overload your cutter. Take into account the size of the motor, cutter size and type, depth and width of cut, and the type of material.

Too rapid a rate of feed will cause the router to overload. Cutting will be difficult to control, and tearout (splintering) is likely. Damage may occur to your router motor or chuck, and in extreme cases your bit could break.

On the other hand, too slow a rate of feed will cause the bit to rub instead of cutting. This shows up as burn marks on your workpiece.

The optimum feed rate will be determined with practice. The cut quality, and the sound of the router motor are guides to the correct feed rate.

Avoid pausing during the cut as you risk developing a slight burn mark or step in your work.

It is always best to first do a “dummy run” with the power off to ensure that you can complete the cut smoothly without obstruction.

The Depth of Cut

As a general rule, when using small, straight cutters (up to 10mm / 3/8" in diameter) make sure that the depth of cut does not exceed the diameter of the bit. With larger diameter bits it is generally better to make two or three shallow cuts rather than one deep cut.

Router Bits

Routers operate at free-running speeds of between 18,000 and 24,000 rpm. If you want consistently clean cuts, free of burn marks and tearout, sharp cutters are essential. We do not recommend high speed steel bits because they generally do not retain their sharp edges for long.

We recommend that you purchase tungsten carbide tipped router cutters. Tungsten carbide is the hardest commercially available cutting edge material. You may like to consider Tritons own range of Premium Carbide Tipped Router Bits.

When profile cutting or edge trimming, look for bits which have a ball bearing pilot on top. Bits which have an integral pilot (i.e. no ball bearing race) often burn or mark the work.

OPERATION

General Points

- The main **calibration scales on the table are for reference only**. They do not relate to any actual dimensions, which are determined by the diameter of the cutter used.
- Unlike the saw's rip fence **the router fence does not have to be locked parallel** on the table. The readings in both fence windows may differ.

- **Wherever possible use both side pressure and down pressure fingers.** When they cannot be used ensure the workpiece is pressed down on the table and against the fence during the cut.
- It is always best to **do a test run first** on an offcut of the material you will be working with, to ensure the desired cut is achieved.

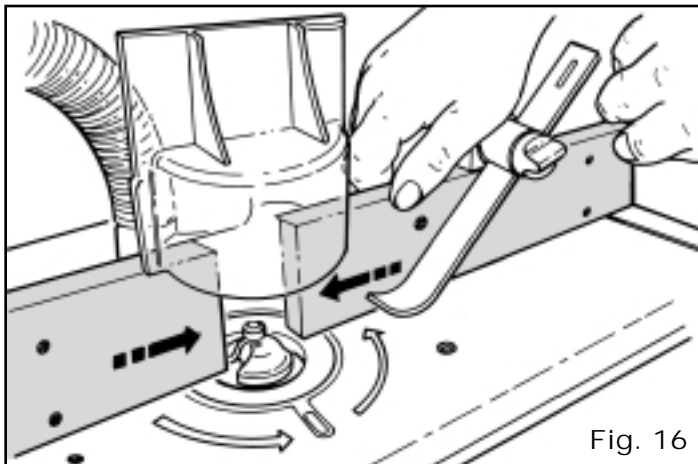

Fig. 16

- **When using narrow cutters or when working on small components, slide the MDF fence faces toward each other** until they just clear the cutter. This provides maximum support for the workpiece, close to the cutter. **Fig. 16**
- When using cutters larger than 25mm (approx. 1") diameter and less than 50mm (approx. 2") replace the small table insert with the larger size.
- If the power switch on your router does not permanently lock on, use tape or a releasable cable tie to hold the switch on during operation. Alternatively a trigger strap (part no. AGA001) can be ordered through your local Triton stockist.

Dust Extraction

Connecting your Router Table to a vacuum source is highly recommended. While dust extraction can be achieved using any vacuum cleaner, domestic (bag-type) units can fill up very quickly. For a much larger capacity, consider fitting a Triton Dust Collector (DCA300) to your vacuum cleaner.

Push-fit the Vacuum Hose (2) over the dust port in the overhead guard and screw the Tapered Hose Adaptor (4) onto the opposite end of the hose. Note that it has a left-handed thread. When in use, firmly plug the wand of your vacuum cleaner into the tapered hose adaptor.

The Router Table can be used without dust extraction. If doing so use of the larger diameter table insert will help wood shavings to fall beneath the table. Ensure shavings do not build-up between the fences and your workpiece. Brush or blow away accumulated shavings after every few cuts, **when the cutter has stopped spinning completely.**

The combined electrical load of your router and vacuum cleaner may exceed the rated amperage of your domestic extension lead or power outlet. Therefore you should always connect your vacuum cleaner and router to separate electrical outlets, and switch on both appliances separately.

EDGE REBATING

Edge rebates are generally performed using a straight cutter, however, if using a bearing guided rebate cutter refer to "Edge Moulding". The router fence should always be fitted when edge rebating. **Fig. 17**

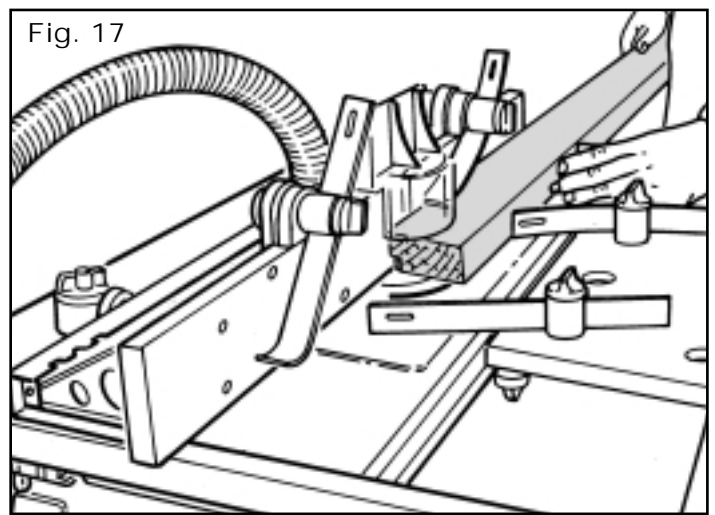

Fig. 17

Start by setting the router fence flush with the cutter. Use a wooden straight edge along the fence face and rotate the cutter until its cutting edge is in the outer most position. Adjust the fence until the front and rear scale readings are similar and the straight edge is touching the cutter. Lock the fence.

When rebating to match the thickness of a component (eg. a cabinet backing) use an offcut of that component to set up the cut as follows:

- Set and lock the router fence flush with the cutter.
- Install the micro-adjusters in the table slot behind the fence but do not yet tighten them into position.
- Place your offcut between the back flange of the fence and the micro-adjusters then tighten them into position.

Fig. 18

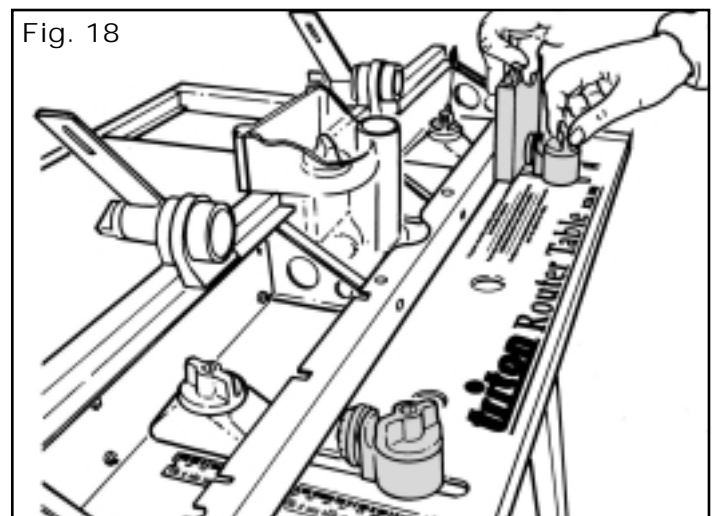

- Remove your offcut, re-position the fence back against the micro-adjusters and lock it.

When rebating to a required dimension use the fence scales as a reference or use the micro-adjusters as follows:

- Set the router fence flush with the cutter.
- Screw the thumbwheels on the micro-adjusters out to provide sufficient adjustment.
- Tighten the micro-adjusters in position against the rear of the fence and screw the thumbwheels in the required rebate amount. One complete turn is 1.0mm and calibrations are marked every 0.2mm. ($1/32$ " = 0.8mm, $1/16$ " = 1.6mm, $1/8$ " = 3.2mm, $1/4$ " = 6.4mm)
- Unlock the fence, move it back against the micro-adjusters and re-lock.

For short edges the fence should only be used to set the rebate depth and the protractor used to guide the workpiece. See "Cross-trenching". The fence must be set exactly parallel for this operation.

TRENCHING

Warning: For many trenching operations the cutter cannot be guarded. Keep your hands well clear and never trail your fingers behind the workpiece.

Trenching Against a Fence

For trenches up to 100mm (4") in from the edge of a workpiece the router table fence can be used. **Fig. 19**

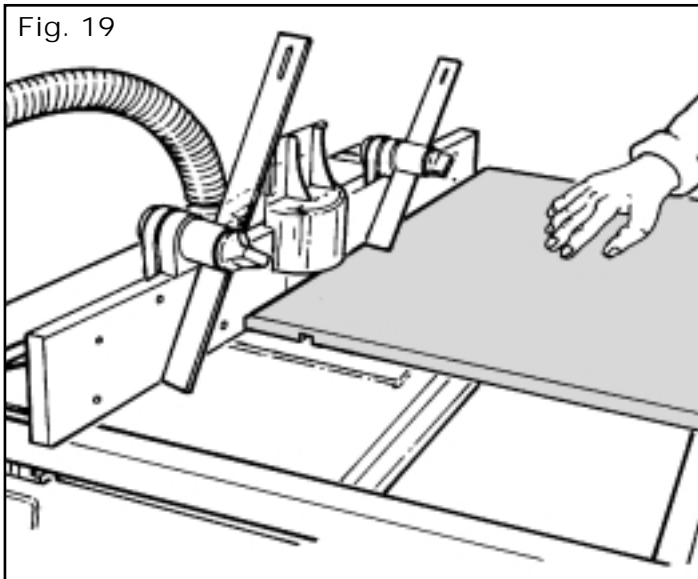

When the Router Table is fitted to a Triton Series 2000 Workcentre trenches up to 610mm (24") in from an edge can be performed against the rip fence.

Trenching larger workpieces against a fence can be achieved on any model Triton Extension Table when the Router Table is fitted to a Workcentre. Sliding models should be used in the "Fixed Rip" mode.

If using a Triton Router Stand - RSA 300, you may consider the optional Mini Sliding Extension Table (ETA100) used in the "Fixed Rip" mode. The compact design fits quickly to the new stand and makes many difficult cuts easy. **Fig. 20.**

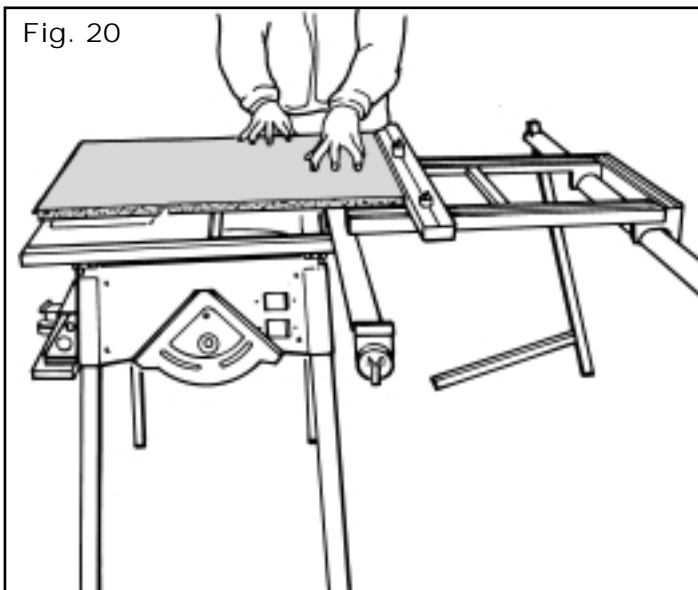

Many trenching cuts can also be achieved using the jig shown in "Planing to a Width". **Figs. 30 & 31.**

Set your router to the desired rebate depth and lock your fence at the required setting. Smoothly feed the workpiece through the cutter and against the fence while keeping it pressed down evenly against the table.

Cross-trenching

Cross-trenches up to 200mm (8") long can be performed with the protractor following the workpiece. Attach a wooden batten with screws through the keyholes in the face of the protractor and extend it past the cutter. Run the batten through the cutter to create a sighting notch and to prevent tear-out in your workpiece. **Fig. 21**

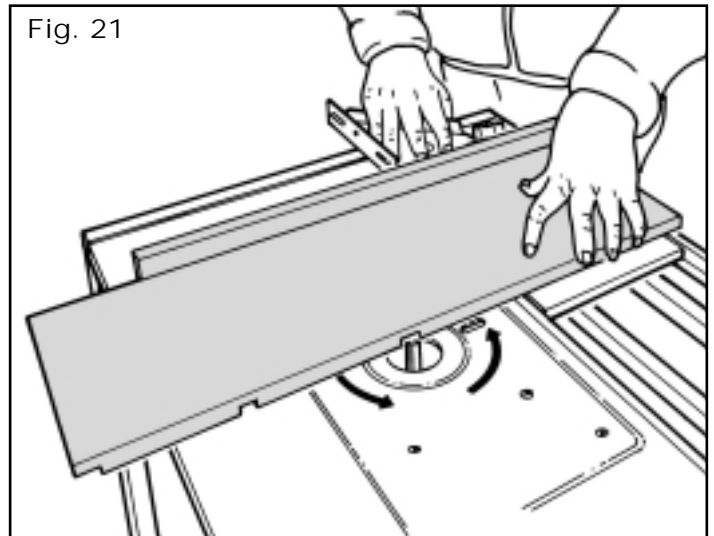

Cross-trenches up to approximately 610mm (24") long can be performed in the overhead mode on the Workcentre using the optional Router & Jigsaw Mounting Plate (AJA150). **Fig 22**

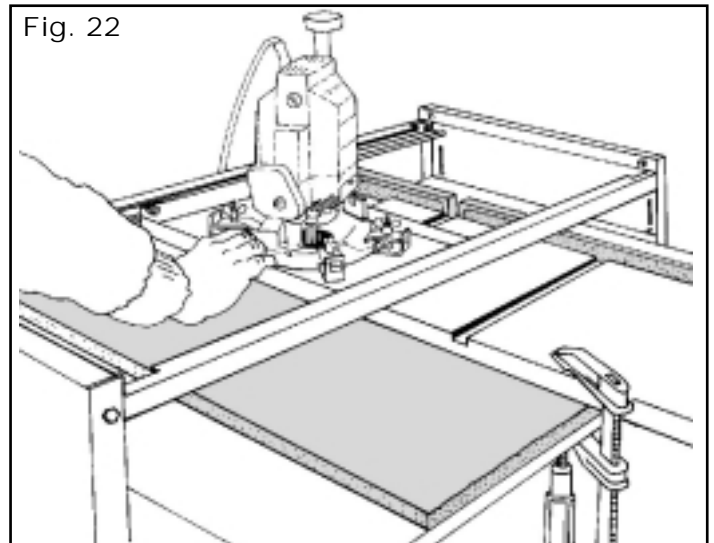

For cross-trenching large workpieces use a Sliding Extension Table in the "Panel Saw" mode. Clamp an extended wooden batten in front of the rip fence using the hold-down clamps and run it through the cutter to provide a sighting notch and prevent tear-out. **Fig 23**

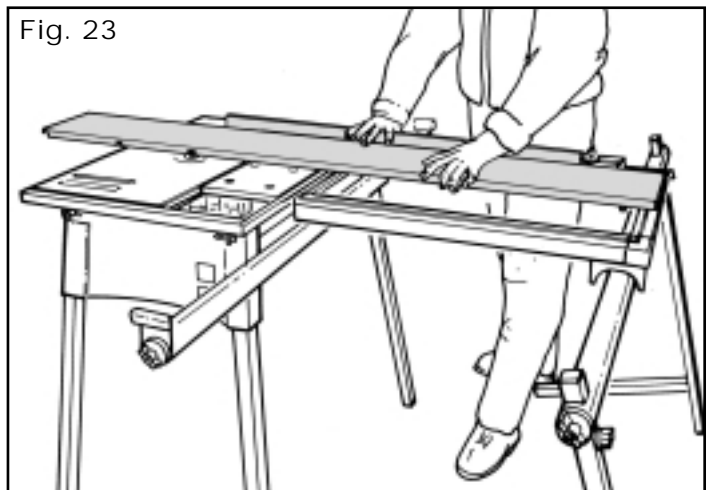

Stopped Cross-trenches

Stopped trenches can be achieved on the MDF slider by placing suitable length spacer boards in front and behind the slider to limit its travel. **Fig. 24**

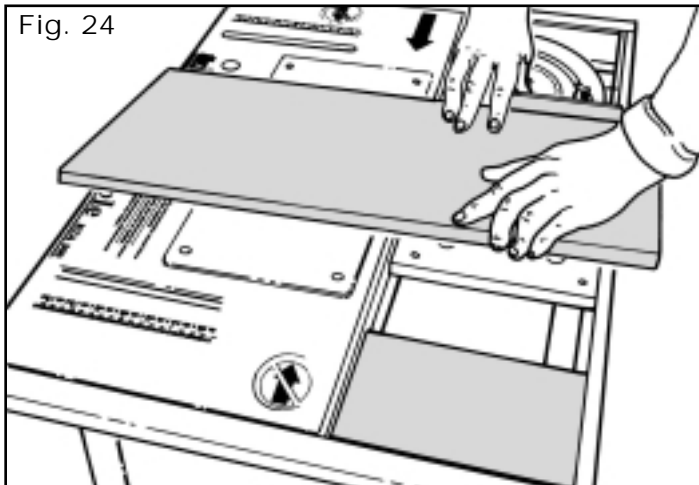

They can also be performed on a Sliding Extension Table by fitting stops (eg. hose or exhaust clamps) to the inner track to limit the table travel.

Cross-trenches which are stopped at both ends require the work to be plunged onto the cutter. While this can be achieved using the above methods, it is best performed in the overhead mode on the Workcentre using the optional Router & Jigsaw Mounting Plate (AJA150).

When completing a stopped trench never drag your workpiece back with the router still running. Switch it off and wait for the cutter to stop spinning.

PLANING WITH A ROUTER

Warning: NEVER make planing cuts with the workpiece passing between the cutter and fence on the right. The cutter will flex aside, "climb up" on the work, and rip the workpiece out of your hands - or pull your hand into the cutter.

Planing cuts should be performed with the cutter mostly hidden behind the fence faces.

Planing on the Router Fence

Planing cuts of 0.5, 1.0, 1.5 & 2.5mm can be performed using combinations of the 1.0 & 1.5mm planing shims supplied. You can use your own shims to achieve other planing cuts.

- Push the spring-loaded MDF face away from the fence and slot the shims into the gap created, straddling each set of screws (loosen spring tension if necessary). **Fig 25**

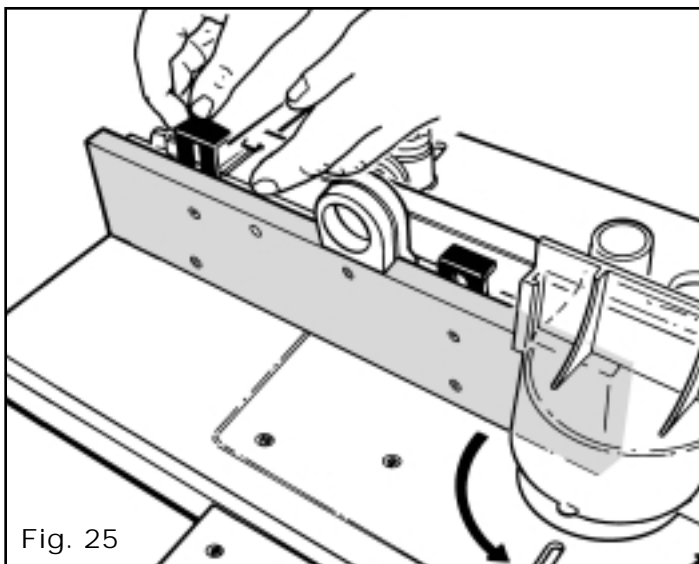

- For 1.0, 1.5 or 2.5mm planing cuts fit the appropriate shims behind the rear MDF fence face. For 0.5mm cuts fit the 1.5mm shims behind the rear MDF fence face and the 1.0mm shims behind the front MDF fence face.
- Use a wooden straight edge to align the cutter blade with the rear MDF fence face. **Fig 26**. Begin your cut.

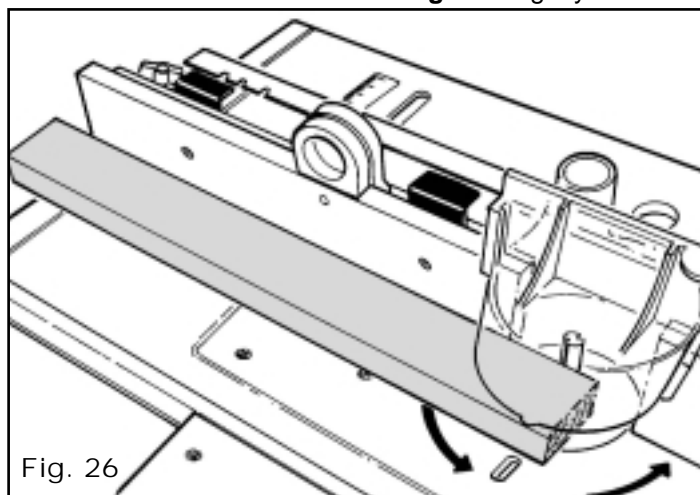

Planing a High Face on the Router Fence

For high face work remove the front guard and position the guard guide back behind the fence. The pressure finger assemblies must also be removed from the fence.

High face cuts require two passes. For 1.0 & 1.5mm cuts insert the appropriate shims behind the rear MDF fence face. Lock the fence with the rear face aligned with the cutter, as described above. Remove the shims and without re-adjusting the fence complete the first pass. **Fig 27a**. Re-fit the shims behind the rear MDF fence face, flip the workpiece and complete the second pass. **Fig 27b**.

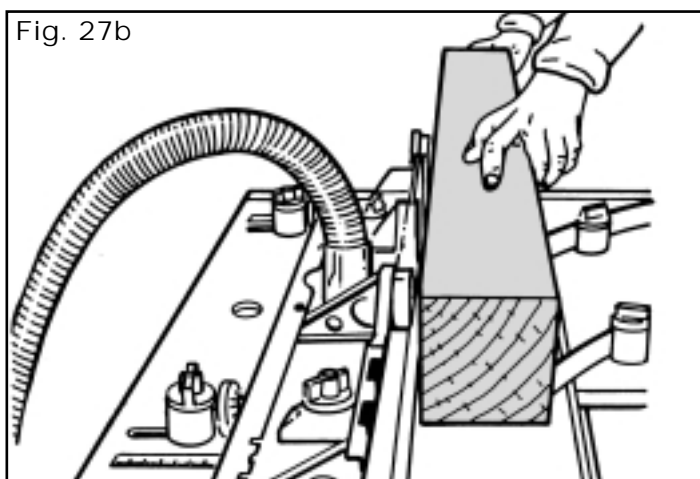
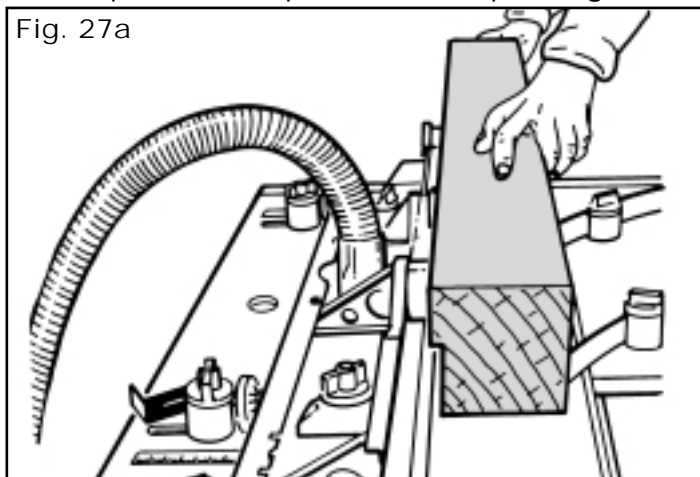

Note: for 0.5mm high face planing cuts use your own 0.5mm shims behind the rear MDF fence face.

Planing to Width

When planing to width remove the router fence and relocate the safety guard onto the router plate. To remove the guard first adjust the MDF faces out to their furthest setting. Lift the red lock tab at the rear and depress the catch to remove the guard from the fence, then re-fit it to the table. Reposition the front guard back until it is flush against the rear guard.

Fit the side pressure fingers to the table holes with spacers reversed, as described in assembling the "Pressure Fingers" (Fig. 13). The straight pressure fingers should be fitted.

Planing to width is performed using a fence on the left side of the cutter (when viewed from the switchbox end), therefore a Series 2000 Workcentre, Extension Table or planing jig is required.

Small planing cuts provide a better result. Aim for less than 3mm ($1/8$ ") with each pass.

Using the Series 2000 Workcentre fence

Position the rip fence until it is touching the cutter and the scale readings are the same front and rear. Subtract this scale reading from your desired planing width to obtain the required fence setting.

Alternatively, place your workpiece between the cutter blade and rip fence and adjust the fence until the scale readings are approximately equal front and rear. Remove the workpiece, reset the fence toward the cutter by the desired planing amount and commence your cut. Fig 28

Fig. 28

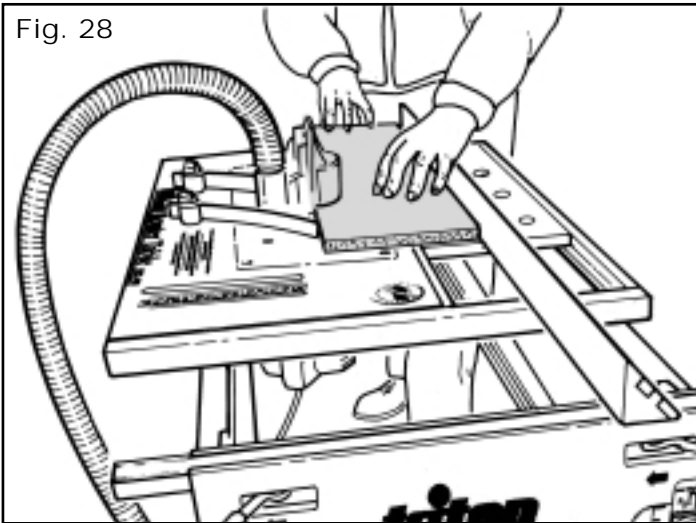

Using an Extension Table fence

Sliding models should be used in the "Fixed Mode" when planing to a width.

Fig. 29

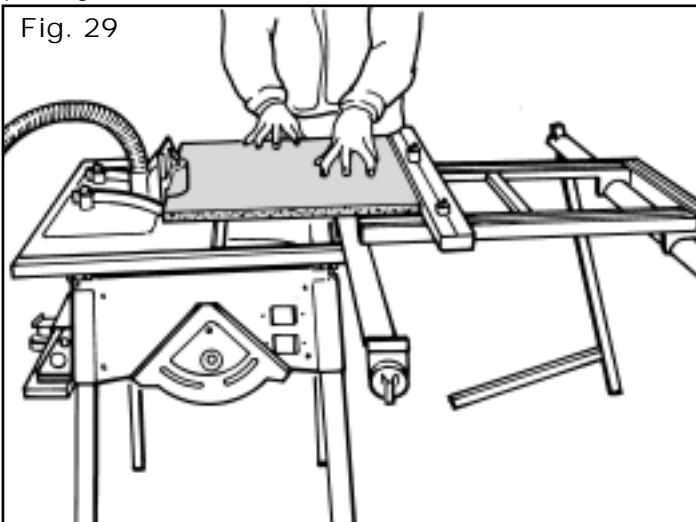

Wide workpieces can be planed directly against the extension table fence, however narrower workpieces will require a spacer board between the fence and the workpiece.

Lock the fence parallel at a convenient scale setting and measure the distance between the cutter and the fence. Use this figure to calculate the fence setting for your desired planing width.

Alternatively, place your workpiece between the cutter and the fence and adjust the fence until the scale readings are approximately equal front and rear. Remove the workpiece, reset the fence toward the cutter by the desired planing amount and commence your cut. Fig 29

Using a Planing Jig

To make a planing jig cut two boards from 19mm sheet material to fit perfectly within the table slider opening. Rebate the edges of one board (the base board) to accommodate the slider tracks and ensure the jig sits flush with the table. With the router fence set at maximum width make a slot in the base board using a $1/2$ " diameter straight bit. Slot a little over half way through the board then flip it and make a second slot. The other board should be slotted in the same way using a $1/4$ " diameter bit. Fit the jig base to the table and use the router fence clamping knobs and T-bolts to join the top to it. The full range of adjustment can be achieved by rotating the jig base and/or jig top. Fig 30

Fig. 30

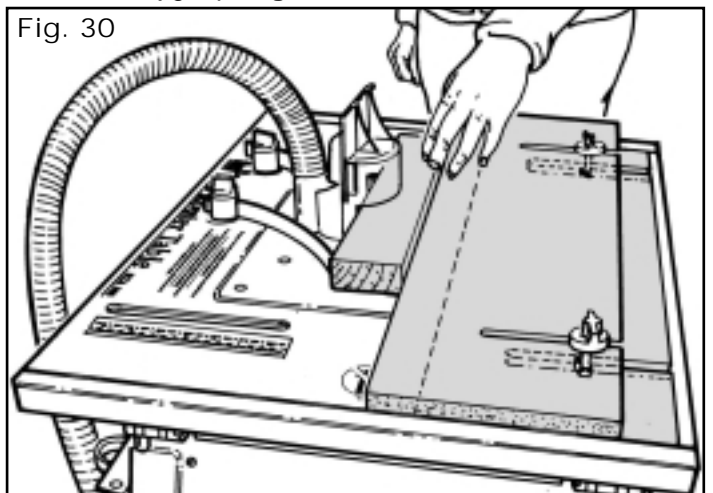

Place the workpiece between the cutter and the jig and lock the jig. Remove the workpiece and reset the jig top towards the cutter by the desired planing amount.

Depending on the position of the jig you can use the micro-adjusters in the jig slots to set the width either by using the thumbwheels or the fence shims, as described in "Planing". To increase the useful range with the micro-adjusters the jig fence can be replaced with a narrow batten. Fig 31

Fig. 31

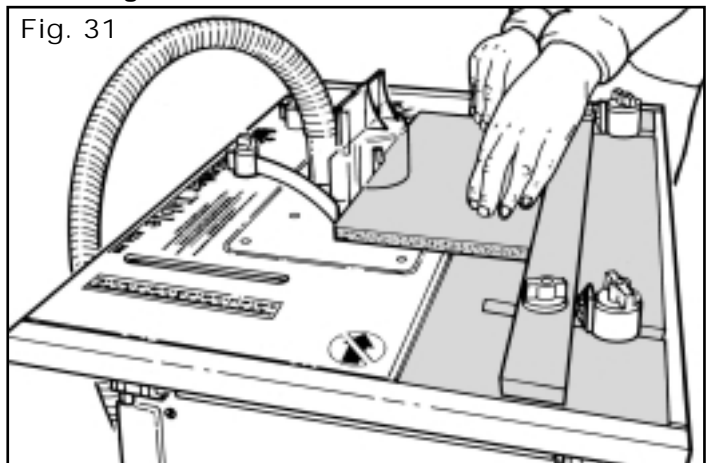

EDGE MOULDING

Decorative cutters commonly have a ball bearing or plain pilot on top, which can be used without a fence. However, straight sided or slightly convex workpieces are more easily edge moulded using the fence. **Fig 32**

For concave or complex shapes remove the fence and fit the guard to the router plate. **Fig 33**

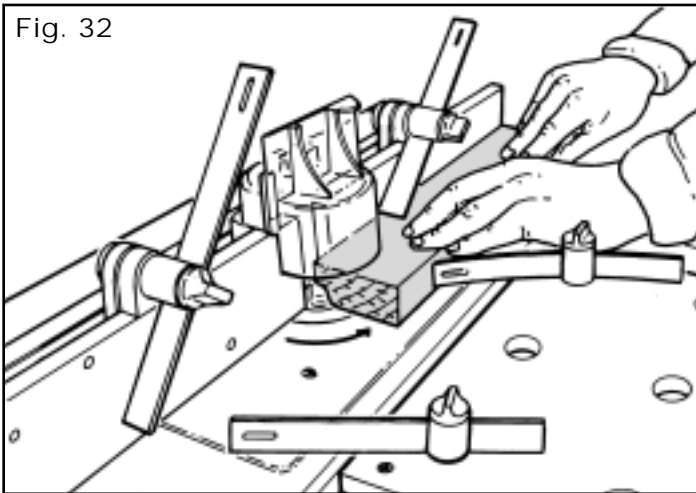

Fig. 32

Using the Router Fence

It is always best to use two or three shallow passes rather than one deep pass to lessen the chance of tearout or splintering.

Adjust the fence to just expose the cutter for the first pass. Progressively expose more of the cutter by adjusting the fence between passes until the final pass when the pilot should be level with the fence.

For extra support and guidance short edges are best performed against the protractor. See "End Grain Work".

Free-hand edge moulding

Warning: Never attempt free-hand routing without a bearing or pilot guided cutter.

Always use the guard as it makes the job safer and the integral lead-in and trail-out guides makes the job much easier as well.

Several passes are better than one deep pass. Start with the cutter lowered and progressively increase the cutter height for each pass.

Rest the workpiece against the front (lead-in) edge of the guard and keep it in contact with it while feeding the workpiece onto the cutter. Continue the cut against the cutters pilot guide then near the end of the cut swing the workpiece toward the rear (trail-out) edge of the guard. Complete the cut with the work in contact with the rear edge of the guard. **Fig. 33**

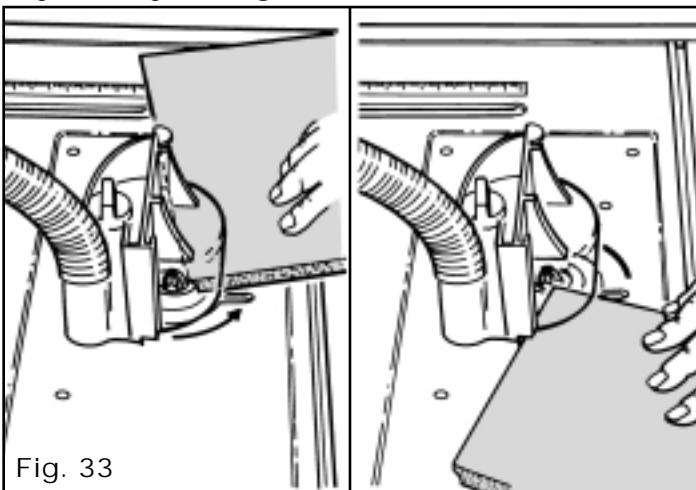

Fig. 33

END GRAIN WORK

Short edges, typically end grain, are not easily controlled against the router fence and can often tear-out at the completion of the cut. This can be overcome by using the protractor fitted with an extended wooden face as described in "Cross-trenching".

End grain work using the protractor can be performed with the fence fitted (see "Edge Rebating"), or with the guard fitted to the router plate. **Fig. 34**

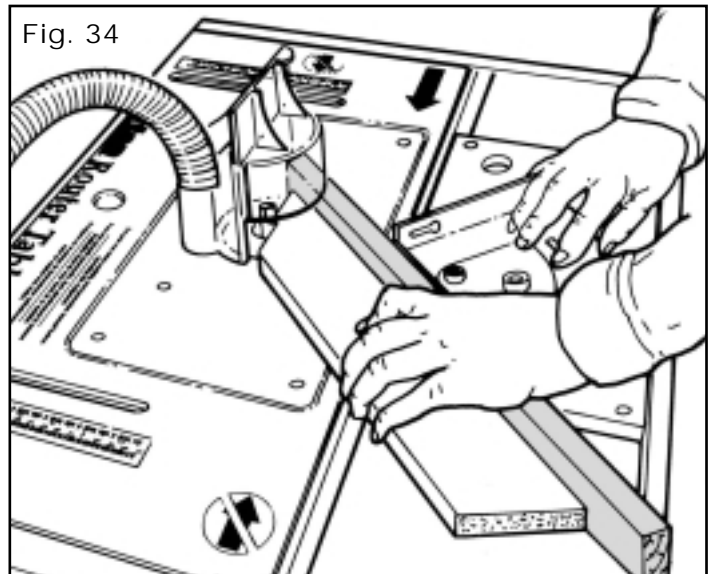

Fig. 34

USING A TEMPLATE GUIDE

Use the guard in the table mounted position whenever possible. For cuts which prevent the guard from being fitted great care should be taken with your hand positions.

Templates are very useful for cleanly finishing the edges of curved or shaped components.

Template routing is achieved using a flush trim bit with top bearing (as used for laminate trimming).

The fence cannot be used in this operation so the guard should be re-located to the router plate.

First, rough out the shape of the workpiece with a jigsaw. Then using tacks or double-sided tape attach the template to the top of your workpiece. Set the height of the flush trim bit so that the bearing runs only along the template. The workpiece will then finish exactly the same size as your template.

Feed against the direction of rotation, and keep both hands well clear of the cutter and on top of your workpiece. **Fig. 35**

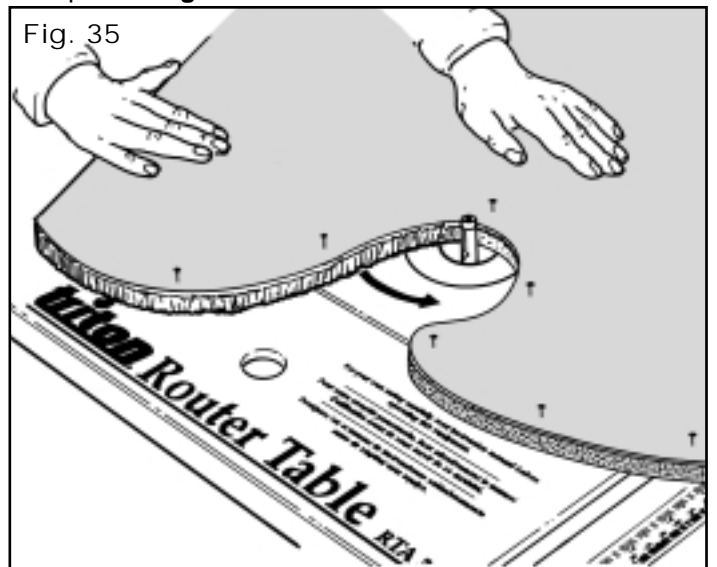

Fig. 35

MORTICING

Warning: The cutter cannot be fully guarded when morticing so ensure your hands are well clear of the cutter at all times and hold the workpiece firmly.

You can cut mortices to house the stub tenons cut with your saw in the Workcentre.

Most mortices will require the front guard and hold-down finger assemblies to be removed from the fence, and the guard guide adjusted back behind the fence face.

Position and lock the fence assembly so that the workpiece will be in approximately the right position above the cutter.

Test the position of the fence by plunging an offcut of your workpiece onto the cutter.

Do not set the cutter too high. It is always best to perform several cuts at increasing settings.

Slide the piece forward along the fence for a short distance. The cutter will tend to push the material away from the fence, so firm sideways pressure against the fence is necessary. Consider using the jig described in "Planing to Width" to hold the workpiece against the fence.

Re-adjust the fence if necessary and repeat the test until satisfied with the position of the mortice.

To establish the beginning and end of the mortice, it is best to work between two stop blocks clamped to the fence. If the workpieces are too long to use stop blocks fitted to the fence, replace the MDF faces with longer ones and fit the blocks to them. **Fig. 36**

With extremely long workpieces (where it is not possible to work between stop blocks) reference the mortice position by drawing lines onto the side of your workpiece and aligning these with pencil lines drawn onto the table to indicate the position of your cutter.

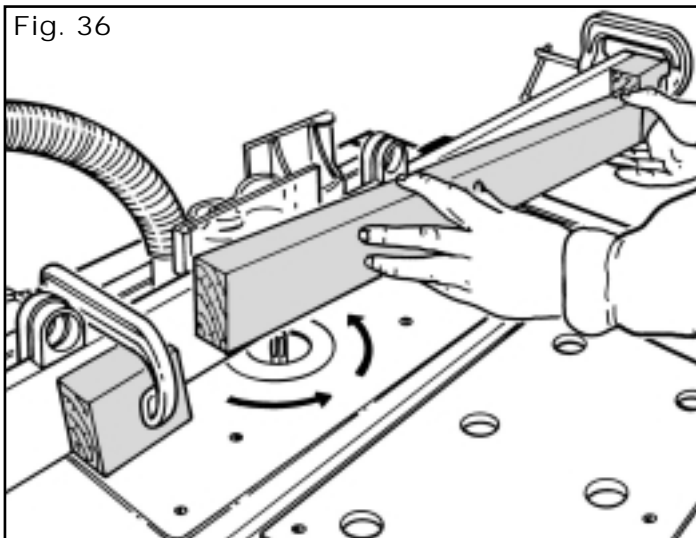

Hint: Don't bother chiselling your mortices square at the ends. Round off the tenons instead. You will find it easier.

RECOMMENDATIONS FOR ROUTER SELECTION

If you haven't yet selected a router, or are thinking of upgrading your equipment, here are our recommendations for router selection:

Type

You can basically choose between "plunge" routers and "screw-adjustment" routers. The terms refer to the means of adjusting the depth of cut of the router.

Plunge routers offer faster and easier cutter height adjustment. Some have a three position turret for setting three different routing depths.

Screw-adjustment routers are often cheaper, but they are slower to adjust. However, fine-tuning adjustment of the cutter depth is often easier and more positive with this type of router.

Size

The Router Table enables the use of $\frac{1}{4}$ ", $\frac{3}{8}$ " and $\frac{1}{2}$ " chuck routers. $\frac{1}{4}$ " routers are generally small, lightweight units with power ratings of up to 1 HP. They are effective as long as they are not overloaded in use. However there are limitations to the size and especially the length of the cutters that can be fitted. On the other hand, their light weight makes them ideal for hand-held use, and this could be an important factor in your decision.

$\frac{3}{8}$ " routers and router bits are not commonly available. If you buy a $\frac{3}{8}$ " router, you will probably need to fit a reducing collet so that you can use $\frac{1}{4}$ " bits

If your router will be mostly used in the Router Table, and you can justify the cost, we recommend that you consider a $\frac{1}{2}$ " router. They are built for heavy, professional use.

A greater range of long shank and/or large profile bits is available on a $\frac{1}{2}$ " shank. Smaller shank router bits ($\frac{1}{4}$ " and $\frac{3}{8}$ ") can be used by fitting the appropriate reduction collets usually supplied with the router.

Due to our company policy of continuous product improvement, specifications may change without prior notice.

Made in Australia by: Triton Manufacturing & Design Co. Pty. Ltd. ACN 000 195 951 ABN 43 000 195 951
14-18 Mills St, Cheltenham, Vic. 3192 Ph: (03) 9584 6977 Fax: (03) 9584 5510
E-mail: tools@triton.net.au Web Site: http://triton.net.au

International Offices:

Canada - Toll Free: 1 888 874 8661
Japan - Free Call: 0120 171 079
New Zealand - Ph: (09) 415 2545

South Africa - Free Call: 0800 600 432
United Kingdom - Free Call: 0800 856 7600
USA - Toll Free: 1 888 874 8661