



SUPERNOVA² CHUCK INSTRUCTION MANUAL

Note: this is a quick reference guide designed to provide a quick overview of the basic information. For a complete instruction manual, videos, guides and other information, please refer to our website.

Thank you for purchasing your SuperNova² Chuck - the latest addition to our Woodturning Chuck range. We are confident that it will be a great aid towards fast workholding and enhance your woodturning capability. The SuperNova² is designed for a range of woodholding modes while being quick and easy to use.

YOUR SAFETY

IMPORTANT PLEASE READ & UNDERSTAND THIS INFORMATION BEFORE USING YOUR SUPERNOVA² CHUCK

DANGER: THIS CHUCK IS CAPABLE OF CONTRIBUTING TO SERIOUS INJURY, AS WITH ANY OTHER POWERTOOL ACCESSORY, IF USED IMPROPERLY ON THE LATHE.

Before using the SuperNova²Chuck, read and understand this instruction manual. Read and understand also the lathe owner's manual. If you do not have a manual, contact the supplier of your lathe to obtain one before using the lathe and Chuck.

User must be professionally trained to use this chuck. Vocational school courses recommended. As with other chucking methods, an extremely cautious and sensible approach is necessary. With the SuperNova²Chuck it is not possible to give exact directions as to the amount of tightening pressure required for workholding. Follow closely strict guidelines in this manual for different jaw types on wood blank diameters and length, plus turning speed.

BEFORE USING SUPERNOVA²CHUCK MAKE SURE THAT -

- EYE PROTECTION WHICH COMPLIES WITH CURRENT ANSI STANDARD Z87.1 (USA) IS WORN. WE RECOMMEND THAT A FULL FACE SHIELD BE USED AT ALL TIMES.
- Chuck is properly secured on lathe spindle. Follow mounting instructions for your lathe for faceplates and other spindle fixtures.
- For safety, DO NOT ROTATE CHUCK UNDER POWER WITHOUT WOOD BEING GRIPPED.
- **WARNING:** EXCESSIVE SPEED IS A SERIOUS LATHE HAZARD. ALWAYS TURN AT THE SLOWEST SPEED POSSIBLE.
- Speed will vary with wood blank size. The larger the blank the slower the speed. Consult your lathe manual or lathe information plate for speed guidelines.
- DO NOT ATTEMPT TO USE THE CHUCK UNLESS THE LATHE SPEEDS ARE KNOWN. YOU MUST STRICTLY FOLLOW THE MAXIMUM SPEED LIMITS SET OUT IN THE OPERATING SECTION OF THIS MANUAL. DO NOT EXCEED THEM UNDER ANY CIRCUMSTANCES.
- EXAMINE WOOD CAREFULLY. ONLY MOUNT WOOD THAT IS SOUND. If any cracks, splits, or weakness is found in wood - DO NOT MOUNT ON CHUCK. DO NOT MOUNT ANY WOOD THAT IS LIKELY TO BREAK UP DURING TURNING (E.G. ROTTEN OR SPONGY WOOD). DO NOT USE POORLY JOINTED/LAMINATED WOOD.
- Make sure wood is clamped firmly. Follow mounting instructions for different gripping modes and jaw types. In the expansion mode do not use undue force or jaws may split the wood.
- Do not exceed maximum guidelines in this manual for wood blank diameters/length set out in this manual for different modes and jaw types. **DO NOT USE WITH ANY COPYTURNER OPERATIONS**
- Check wood is securely held in chuck, before operation. Check grip by vigorously wrenching wood blank back and forth. If any loosening occurs, re-examine holding area for adequate grip (Following mounting guidelines) and any damage to holding area. Rotate manually to make sure of clearance before switching power on.
- **WARNING FOR SAFE OPERATION. DO NOT EXTEND JAW SLIDES BEYOND CHUCK BODY UNDER ANY CIRCUMSTANCES.**
- Irregular or out of balance stock needs to be turned at the slowest possible speed until it is in balance. For use on outboard/left-hand rotation - MAKE SURE INSERT IS SECURELY LOCKED WITH GRUBSCREW BEFORE USE. Use only hand held woodturning chisels to shape wood being held in chuck.
- USE THE RIGHT CHISEL FOR THE JOB AND DO NOT FORCE TOOLS. Use safe and commonly approved chisel techniques. **Wherever possible stand to one side of the revolving wood.**
- WEAR PROPER CLOTHING. Do not wear any loose clothing, neck ties, gloves, bracelets, rings or other jewellery that could get caught in moving parts. Wear protective hair covering to contain long hair.
- DRUGS, ALCOHOL, MEDICATION. Do not operate chuck or lathe while under the influence of drugs, alcohol or any medication.
- KEEP CHILDREN AND VISITORS AWAY. All children and visitors should be kept safe distance from the work area.

Make workshop childproof with padlocks, master switches, or by removing starter keys.

REMOVING AND ATTACHING JAWS TO THE SUPERNOVA²

The Supernova² chuck comes without jaws attached. With the many jaws available it is very easy to use your single chuck for a very wide range of applications. All jaws in the Teknatool range for the Supernova² are secured and attached the same way.

Attaching Jaws - To mount the jaws to the Supernova² chuck is another easy process. Firstly wipe clean all jaw slides making sure a clean contact will ensure. Repeat this with all four jaws you wish to attach. Jaw slides are numbered one to four and have a corresponding jaw - of the same number (identified by the number of dots on the locating ring). Place a jaw on its correct jaw slide and position into the groove (location ring out from the jaw into the groove of the jaw slide). The first few times you may need to GENTLY tap the jaws into the locator slot with a block of wood or plastic mallet. Place M6X6 counter sunk screws in jaws and screw them to finger tight (a little grease smeared under screw head at this stage will assist in easy removal later) When both screws are in nip them up and back them off half a turn. Repeat this the remaining three jaws, now using the 8mm t bar Allen key scroll all jaws towards middle until they all come together. Now with all jaws lightly touching and exerting equal pressure on each, tighten all screws up. This will ensure a perfect run out. Check to see there are no gaps between the jaws if this has happened it will probably be due to a jaw being placed on its wrong number (e.g. a #2 jaw on a #3 jaw slide)

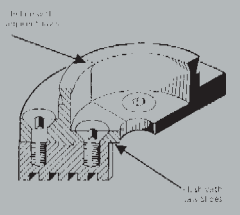

To remove Jaws - Simply using the 4mm Allen key supplied, unscrew all M6 counter sunk screws (there are eight of them). The jaws will come away once their screws are released, however sometimes due to dust particle build up after heavy turning the jaws may need a very light tap with a plastic hammer to dislodge them. It is important to keep them in their set so not to mix them up with other jaws of the same type.

MOUNTING SUPERNOVA² ON THE LATHE

Check that the correct insert has been supplied to match your lathe spindle thread. The code of the insert is on a label on the plastic cover and stamped on one of the flats of the hexagon section of the insert.

Check that the internal spigot of the chuck body plus insert threads are clean and that the spigot end of the insert is free from damage. Any dents or nicks must be carefully filled off so the insert can be fully screwed home in the chuck body. The tolerances of the chuck body and insert are a tight fit to ensure accuracy. This means that the insert may be difficult at first to engage with the chuck body thread. One way is to grip the chuck body in a vice (pad against damage) and screw in insert using the optional accessory spanner or a 1 1/2" spanner. Care needs to be taken that the outer male insert thread is engaged properly at the start with the female body thread. Screw insert fully into body recess. This is important to ensure accurate running. The insert can now be locked to chuck body by means of the M6X6 grub screw provided. Make sure that the fibre washer is inserted first to act as a buffer between the grub screw and insert thread.

DO NOT SCREW IN GRUB SCREW BEFORE INSERT IS SCREWED HOME IN CHUCK. IMPORTANT : L/H THREAD INSERTS MUST BE LOCKED TO CHUCK BODY OR CHUCK BODY COULD UNWIND FROM INSERT. The chuck has a threaded hole in the body for this purpose. The grubscrew can be fitted to this hole.

(continued over page)

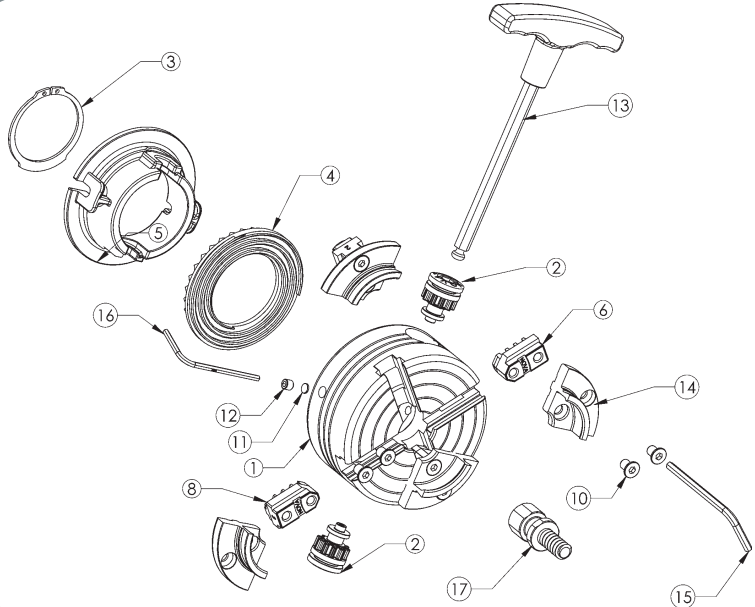

ITEM NO.	QTY.	PART NO.	DESCRIPTION
1	1	23049	Body SuperNova 2
2	2	23081	Machined Cast Pinion
3	1	EC48	Circlip
4	1	23082	Machined Cast Scroll Ring
5	1	23048	Plastic Backing Plate
6	1	23051	Jaw Slide 1
7	1	23052	Jaw Slide 2
8	1	23053	Jaw Slide 3
9	1	23054	Jaw Slide 4
10	8	CM5010181	Screw C/Sunk
11	2	NS1000	Washer Fibre
12	1	G0606	Grubscrew
13	1	13006	Handle
14	4	10029	Jaw Set 50mm
15	1	AK4	Allen Key 4mm
16	1	AK3	Allen Key 3mm
17	1	10006	Woodworm

(continued from page over)

Correct fitting of chuck to lathe spindle is important to ensure accuracy. The chuck body must contact an accurate shoulder on the lathe spindle or bearings (as on Teknatool DVR & 3000) to ensure chuck will run true. There can be a wide variety of lathe spindle thread and spigot dimensions even within the same thread size. The internal thread size is kept to standard tolerances. The internal thread length and spigots of Supernova inserts are manufactured to cover as wide a range of variations as possible. This will mean that in most situations you should be able to get a satisfactory match.

Check the following - Although the insert may screw on part way it may not contact properly with spindle spigot - a spacer or some further modification of the insert may be necessary. This would be the responsibility of the chuck user. Make sure the chuck is screwed to lathe thread properly - a good check is to see whether it screws home on the spindle the same as another lathe fixture such as a faceplate. **POOR FIT OF CHUCK TO LATHE SPINDLE CREATES A SERIOUS HAZARD WHERE CHUCK COULD DISLODGE FROM LATHE. DO NOT ATTEMPT TO USE CHUCK UNLESS THE CHUCK IS CORRECTLY FITTED TO LATHE SPINDLE.** Two 6.8mm holes have been drilled into the chuck body in between both pinions. The grub screw can be fitted into either hole. This is so you can insert a small bar and then tap with a mallet or block of wood. This will help to start unwinding the chuck from the insert.

CHUCK OPERATION

The chuck is operated by inserting the 8mm ball-end t-bar Allan key (provided) in either of the two capitulated pinions on each side. This gives advantage when wanting to operate the chuck with deep bowls partially covering the pinions. Refer to exploded version on position of tee bar Allen key.

To contract Jaws - Turning pinion in direction of arrow (anti-clockwise) makes the jaws move inwards (contract) When the action takes up against the piece held give an extra nip so jaws securely engage with wood.

To Expand Jaws - Turn the handle in a clockwise direction to expand jaws. When the action takes up against the piece held give an extra nip so jaws securely engage with wood.

SPIGOT OPERATION

This is where the jaws contract around a wooden spigot for grip. This function is mainly for box, goblet and vase turning, that is, end grain items with a fair degree of overhang.

This situation is one of the most difficult to provide secure holding no matter what fixing method is used. **EXTREME CAUTION WITH THIS OPERATION MUST BE EXERCISED. DO NOT EXCEED 850 RPM FOR THIS OPERATION.** If used properly the SuperNova Chuck however, provides a very powerful and secure grip in this mode.

Instructions below apply to the standard 50mm jaws but the general spigot technique is the same for other jaw types. However, maximum turning speed and recess size varies with different jaw types. Consult accessory jaw manual or instruction sheets.

With the standard set of 50mm jaws a maximum size woodblank of 100mm (4 inches) diameter (NOT spigot size) by 150mm (6 inches) length can be turned. Square timber of same length and between 40mm (1.5 inches) to 50mm and grip of all four jaws into wood.

MAKE SURE YOU HAVE AN ADEQUATE GRIP BEFORE OPERATION by vigorously wrenching the limb mounted on chuck. If any loosening occurs **DO NOT PROCEED** with operation. Repeat tightening procedure and re-test grip.

SPIGOT SIZE:

Standard Jaws will grip a round spigot between 45mm (1 1/4 inches) to 65mm (2 9/16 inches) approx. Square timber between 40mm (1 3/8 inches) to 50mm square approx.

(Note: EUROPE/UK: Maximum size is 6mm (1/4") less).

Jaw slides only: With the 50mm add-on jaws removed, the jaw slides will grip either round or square timber down to 8mm (5/16 inch). Length limits same for spigot work. Small work not greater than this diameter can be turned at a speed NOT EXCEEDING 1800 RPM. Larger work held in the jaw slides should not exceed 850 RPM.

FORMING SPIGOT:

When selecting wood make sure it is sound without splits or weakness - especially around the area where the spigot is to be formed. **REMEMBER WITH FREE END TURNING, THIS IS THE ONLY AREA GRIP. IF ANY WEAKNESS IS FOUND, DO NOT PROCEED.** Mount wood between centres and turn the spigot area. Make the spigot as parallel as possible to maximise the efficiency of the clamping action. Only approximate sizing of the spigot is necessary, as the jaws will accommodate a wide range of spigot diameters within the spigot limits stated above. The 50mm standard jaw has a thin lip or shoulder at the front face. This is designed to bite into the timber as the jaws are tightened. **DO NOT CUT A RECESS FOR THE LIP TO FIT INTO, AS THIS WILL REDUCE GRIPPING POWER.**

DOVETAIL OPERATION

Expansion of the jaws into a recess. This function is for bowl and platter turning where the projection (depth) of the wood blank is not too great i.e. up to 100mm (4 inches). Characteristically these items have a parallel wood grain. **IT MUST NOT BE USED FOR ANY LONG WORK (OVER 100MM) AS THERE WOULD BE GREAT DANGER OF WOOD TEARING OUT AND DISLODGING FROM CHUCK.**

Instructions below apply to the standard 50mm jaws but the general technique is the same with other accessory jaws. However the maximum size of wood blank that can be mounted, the maximum turning speed and recess size varies with the different accessory jaws. Consult specific instructions included for each jaw set.

This strong holding method, using the standard 50mm jaws bowls up to 310mm (12 inches) in diameter can be turned. **DO NOT EXCEED 600 RPM WITH THIS OPERATION. OUT OF BALANCE STOCK MUST BE TURNED AT THE SLOWEST SPEED POSSIBLE.**

50mm jaws: Any recess can be turned between 50mm (2 inches) and 75mm (3 inches) diameter.

EUROPE/UK: Maximum recess size is 6mm (1/4") less.

Choose the diameter which suits your bowl design. However, bear in mind that best work holding will be achieved around 50mm - keep your recesses between 50mm and 60mm where ever possible. Extra care must be taken when turning with recesses above 60mm. The depth of the dovetail recess can be varied according to the size and mass of the workpiece. The larger bowl blanks or softer woods will require a deeper recess up to the maximum of 6mm (1/4 inch). **HOWEVER YOU MUST USE THE MAXIMUM RECESS DEPTH ON ALL RECESSES OVER 64mm (2.5 inches) diameter OR ANY WORK WITH A DIAMETER OVER 150mm (6 inches).**

For smaller lids and thin platters (not exceeding 150mm diameter) only a shallow recess of around 3mm (1/8 inch) is necessary. It will be matter of gaining experience as to what combinations and sizes will best suit.

USING THE WOODWORM SCREW

The woodworm screw supplied with the Supernova 2 chuck is purpose designed for screw chucking. It is a cylindrical screw which maintains its full holding power along the whole length, unlike normal tapered screws. The thin thread form is specially designed to cause minimum damage to wood fibers. They grip better than screws because there is a larger volume of undamaged wood retained within the screw.

The woodworm screw is made complete with the boss section in one piece. The woodworm screw is to be used with the jaws remaining on place on the chuck. This facility is very convenient for remounting work directly onto the jaws after the screw is removed.

To convert to this operation, place the boss section into the centre of the chuck and close jaws into the slots. **BEFORE FINAL TIGHTENING MAKE SURE THAT THE FRONT OF THE BOSS SECTION OF THE SCREW IS SEATED BEHIND AND AGAINST THE 50MM JAWS.** This will prevent any tendency for the boss section to creep forward when the screw is being used.

The front face of the jaws has been machined to provide an accurate backing surface. This is quite an advantage, providing a much tighter fit and wider tolerance for irregularly faced stock. This feature is also quite an advantage when using the screw to mount a bowl for first stage bowl turning - forming the outside of the bowl straight onto the jaws (the screw is first removed) after the recess has been formed.

The woodworm screw provides 19mm (3/4 inch) of thread beyond the jaws. Irregular, rough tree blanks (e.g. small sections of tree limbs) not exceeding the above sizes can be held quite firmly **BUT** caution must be exercised. Check for adequate contact.

DO NOT USE THE SCREW FOR VERY LARGE WOOD BLANKS. Its intended for small bowl and screw chucking work. The maximum capacity which should be mounted on the screw - 250mm (10 inches) diameter X 100mm (4 inches), **DO NOT EXCEED 600 RPM FOR THIS OPERATION,** use tailstock support.

FORMING RECESS

The jaw dovetail has been designed for use with a standard skew scraper. This chisel will make a recess to the angle required. **FOR SAFETY REASONS WE STRONGLY ADVISE AGAINST USING ANY OTHER TOOL.** A profile of this chisel is shown below. It is best to work with a tool, which is already ground, to the correct angle. All that is necessary then is to keep the leading edge of the chisel flat on the wood, moving forward and out to form the recess to the required diameter and depth.

Mount bowl blank on screw as described in previous section. It may be convenient to first mark out with a pencil, a circle on the bowl blank. To mark out the recess diameter with pencil, hold pencil point to desired radius, supported on the toolrest. Then revolve blank by hand thus creating a pencilled circle. However, as specified above, any recess diameter can be made between 50mm (2 inches) - 75mm (3 inches) (standard 50mm jaws) so exact sizing of the recess is unnecessary.

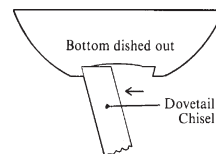

Before scraping out the recess, slightly hollow out the centre of the bowl blank with a bowl gouge or round nose scraper. The purpose is to relieve the centre so that when the recess is scraped out only half the chisel edge needs to be used. We recommend this to reduce tearing of the wood by scraping action; and to make the recess a little more finished to give a better effect to the overall bowl. Extra embellishments can also be made to the recess to enhance the bowl.

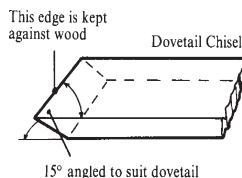

After the recess is finished and the outside of the bowl is turned to shape, wind bowl back off screw. Bowl blank is now ready to be reversed into the jaws. Expand the jaws into the recess. When the jaws are expanded out into the recess, screw the wood blank gently back and forth to make sure it is seated properly on the bottom face of the jaws.

WARNING: MAKE SURE THE JAWS ARE SEATED PROPERLY IN THE RECESS AND THAT THE BOWL IS NOT INCORRECTLY RIDING ON THE FLAT SHOULDER SECTION OF THE JAWS BEHIND THE DOVETAIL. THIS COULD LEAD TO THE BOWL DISLODGING FROM CHUCK. LOOSEN JAWS AND REMOUNT CORRECTLY.

Now give a few gentle raps with the end of a chisel handle or wooden mallet around centre of bowl. Use pinion handle to give an extra nip up. Refer to Chuck Operation. Refer again to safety before operation.

WARRANTY

Serial Number:

You can register your warranty online by visiting www.teknatool.com
This Teknatool warranty is back by a period of twenty-four months from the date of purchase. Teknatool International Ltd hereby agrees to make repairs or replace components without charge for any defects due to faulty material or workmanship, provided that -
a) The warranty period has not elapsed. Proof of purchase date (sales slip, registration of warranty etc) would need to be forwarded to Teknatool International.
b) If, in our opinion, the unit has not already been altered, repaired or modified in any way that would affect its operation; has not been subjected to misuse, negligence, accident or not used strictly in accordance with instructions.
c) Where necessary, transportation is prepaid by the customer to the Factory Service Centre (or other authorised Teknatool Service Centre)
Warranty does not cover costs or damages arising directly or indirectly from the operation of this Teknatool product. No other guarantee, written or verbal is authorised by Teknatool International Ltd.
Our Teknatool Distributors can issue their own warranty to cover this product. Their terms may vary from what is stated above - please check with your dealer if you have any questions. Email our service contact: service@teknatool.com.
Our policy is one of continuous improvement. We therefore reserve the right to change specifications/designs without notice.

For more information contained in a comprehensive manual (along with trouble shooting guides, accessory information etc, please refer to our website)

Copyright 2007

Publication Number: 106-0706-002