

## Assembly Instructions, Montageanleitung, Montážní návod, Instructions de montage PRO-AS1600

<b>A1-30pcs</b>	<b>A2-8pcs</b>	<b>B1-4pcs</b>	<b>B2-4pcs</b>	<b>B3-2pcs</b>	<b>B4-3pcs</b>	<b>C-4pcs</b>	<b>D1-4pcs</b>	<b>D2-4pcs</b>	<b>E-4pcs</b>	<b>F-1pcs</b>	<b>G-1pcs</b>
10x40 mm	8x40mm	5x100mm	5x90mm	4x40mm	6x40mm	M12x100	M12	M12	M12		
<b>H-2pcs</b>	<b>2+2pcs</b>	<b>2pcs</b>									
Wedge for tool well/Holzkeil /Klín koryta											
	Ø 19 mm										

**Attention/Achtung/Pozor:**



**ENG**

Workbench is made of high quality beech wood guaranteeing maximum resistance and long service life of the bench.

**Like all solid wood products it must not be left in areas of high humidity or damp that will cause natural movement.**

Recommended humidity level max. 60%.

If you bought workbench without surface treatment, we recommend you to finish the bench by colourless varnish or oil including the bottom of workbench.

**Please treat your bench with a varnish or oil within 1 months of assembly.** Varnish (oil) prevents absorption of surrounding moisture. **Don't forget to repeat surface treatment each year.**

To increase the rigidity of your workbench ensure that you glue the joints (please read Hint 1 and 2) and bolt the bench in position.

Wood is a natural product, check and tighten all screws and bolts every 6 months.

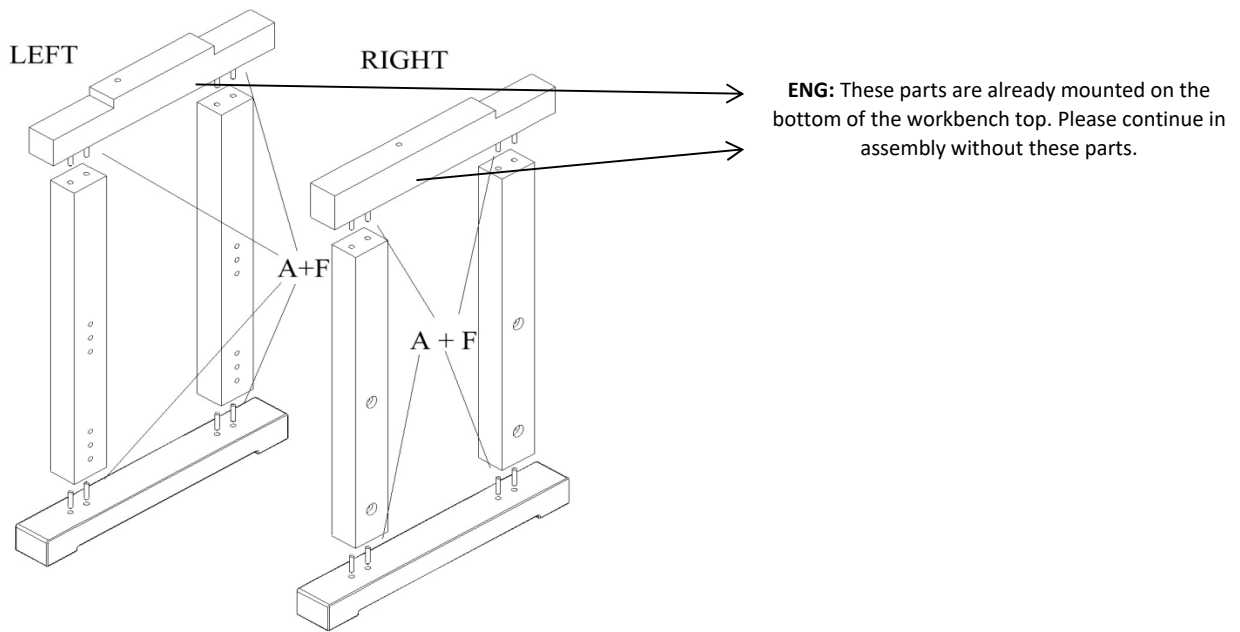

!!! HINT 1 !!! - Don't fill up holes for dowels by glue. Smear dowels by glue and insert them into holes.

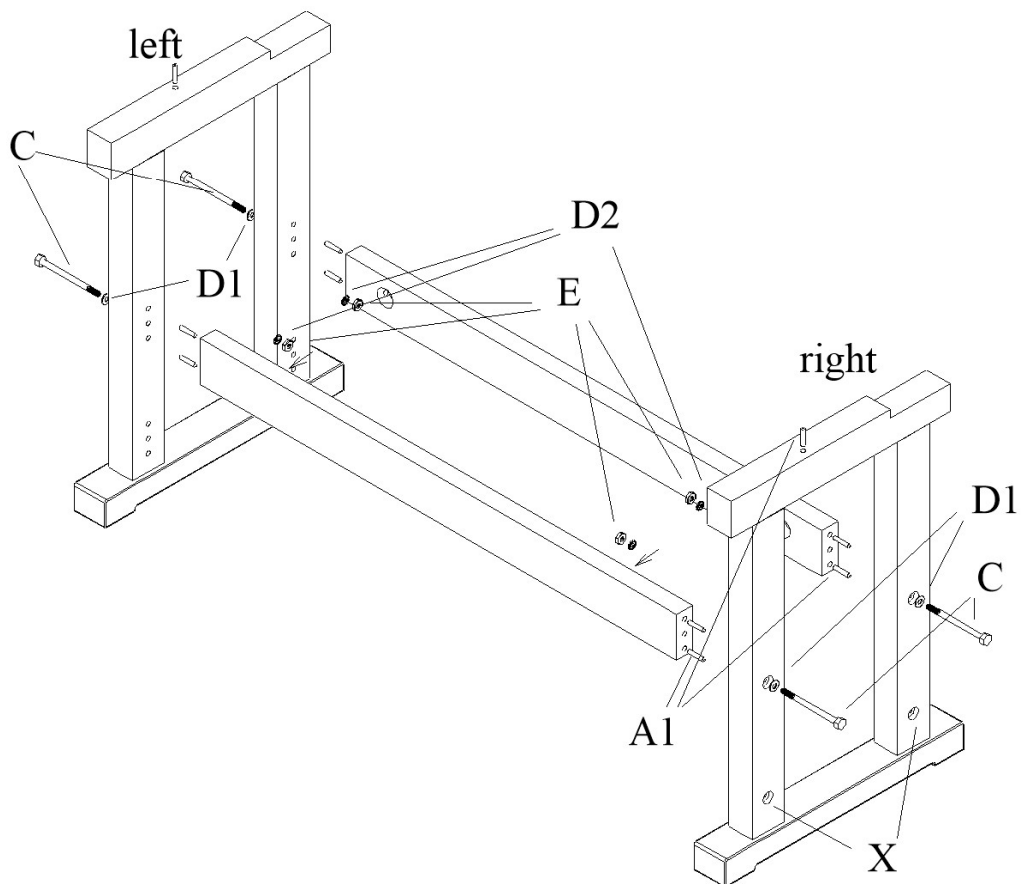

X = holes for stretchers if cupboard is used !!!!

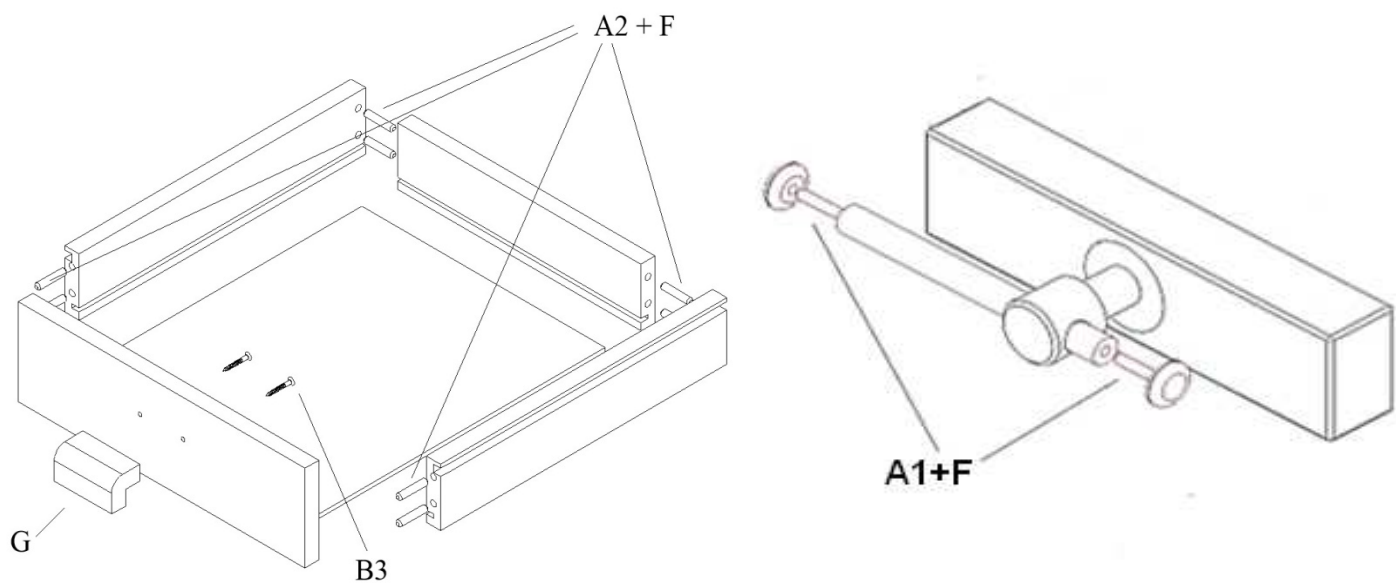

!!! HINT 1 !!! - don't fill up holes for dowels by glue. Smear dowels by glue and instert them into holes.

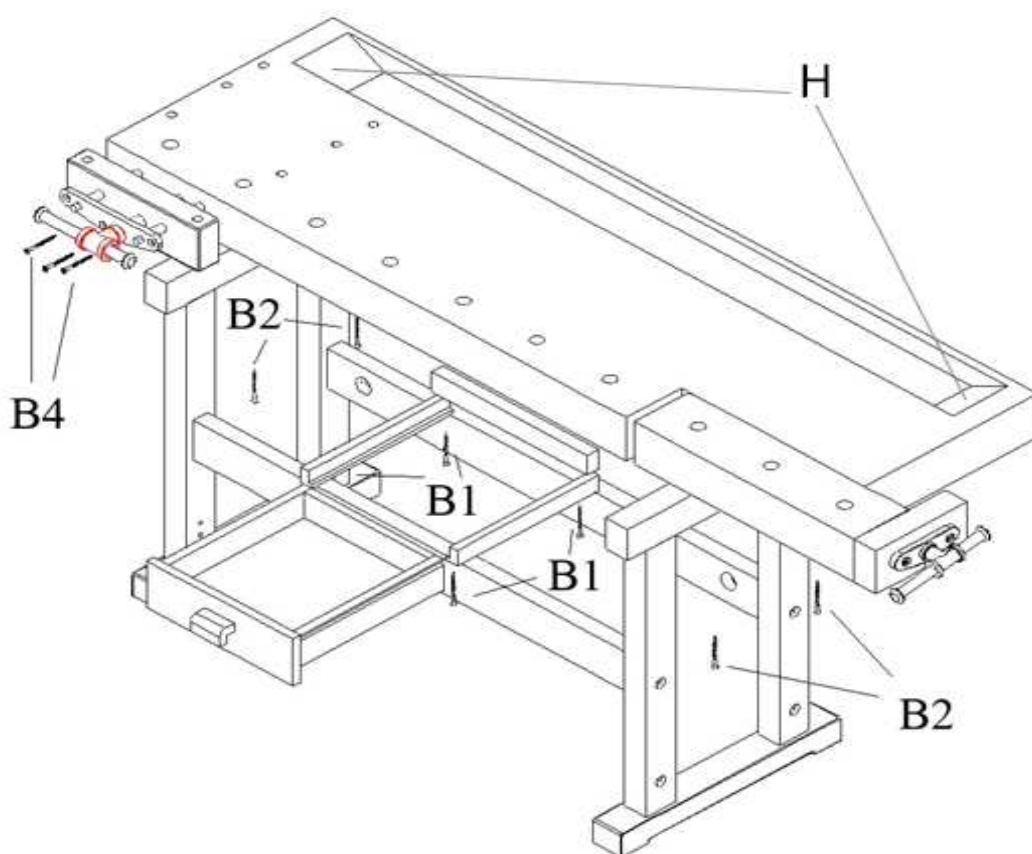

**Important!** Wedges for tool well are supplied separately (part H). Producer recommends to add wedges after approx. 4 weeks. Workbench needs to adapt to the surrounding conditions. In case of need adjust the size of wedges by size of tool well.