

## PRO-ASM 1700 Assembly Instructions

A1-30pcs	A2-8pcs	B1-4pcs	B3-2pcs	B4-3pcs	C-4pcs	D1-4pcs	D2-4pcs	E-4pcs	F-1pcs	G-1pcs	H-2pcs
10x40 mm	8x40mm	5x110mm	4x40mm	6x40mm	M12x100	M12	M12	M12			Wedge for tool well
	2+2pcs		2pcs								
	Ø 19 mm										

**Attention:**

**ENG**

Workbench is made of high quality beech wood guaranteeing maximum resistance and long service life.

**NOTICE:**

The bench must not be left in damp or humid conditions which will cause movement in the wood. **Recommended humidity level max. 60%.**

If you bought workbench without surface treatment, we recommend you to finish the bench by colourless varnish or oil including the bottom of workbench. Varnish (oil) prevents absorption of surrounding moisture. **Don't forget to repeat surface treatment each year including holes for bench dogs.**

To increase the stability of your workbench we recommend you to bolt the bench to the floor. Each 6 months tighten all screws and bolts.

Parts	Packing 1	Packing 2	Date	
-------	-----------	-----------	------	--

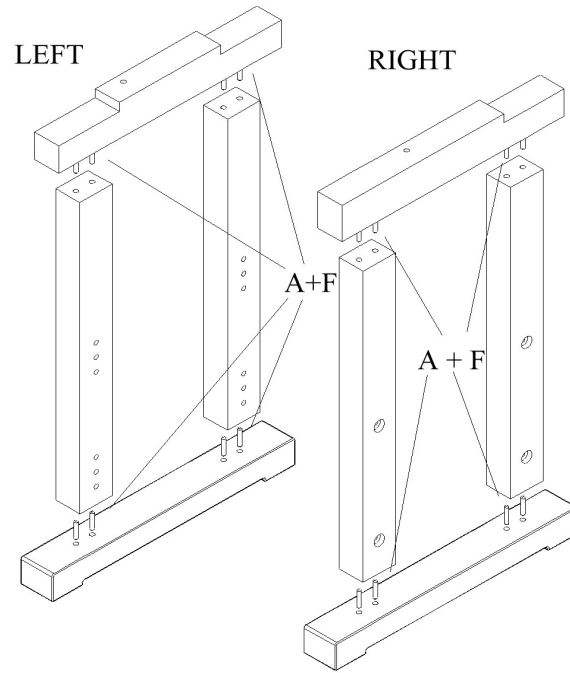

!!! HINT !!! - don't fill up holes for dowels by glue. Smear dowels by glue and insert them into holes.

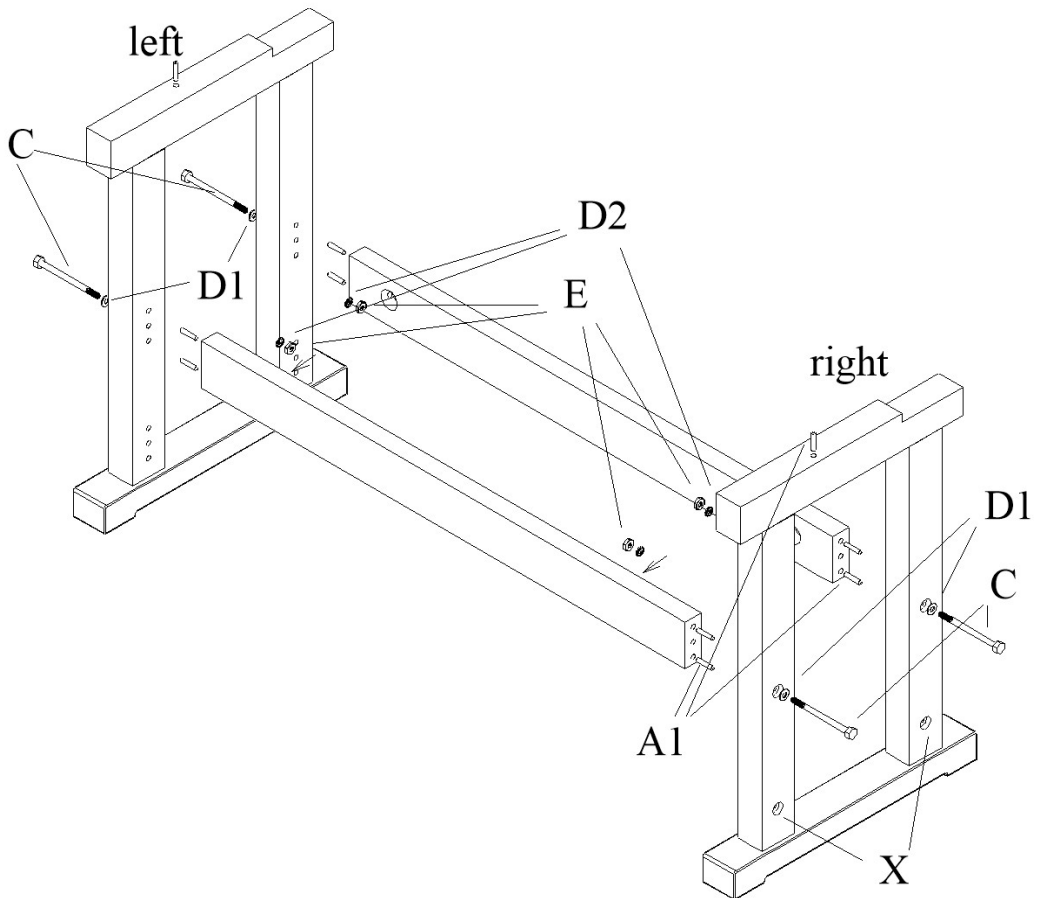

X = holes for stretchers if cupboard is used !!!!

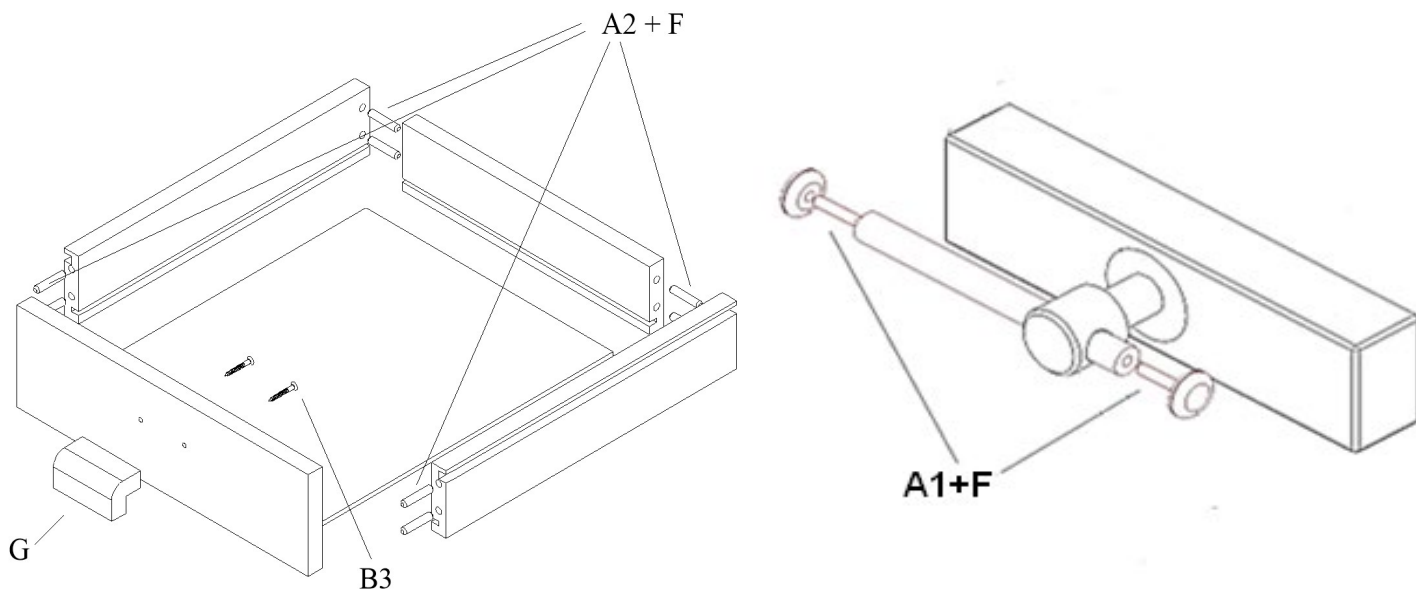

!!! HINT !!! - Do not fill up holes for dowels by glue. Smear dowels by glue and insert them into holes.

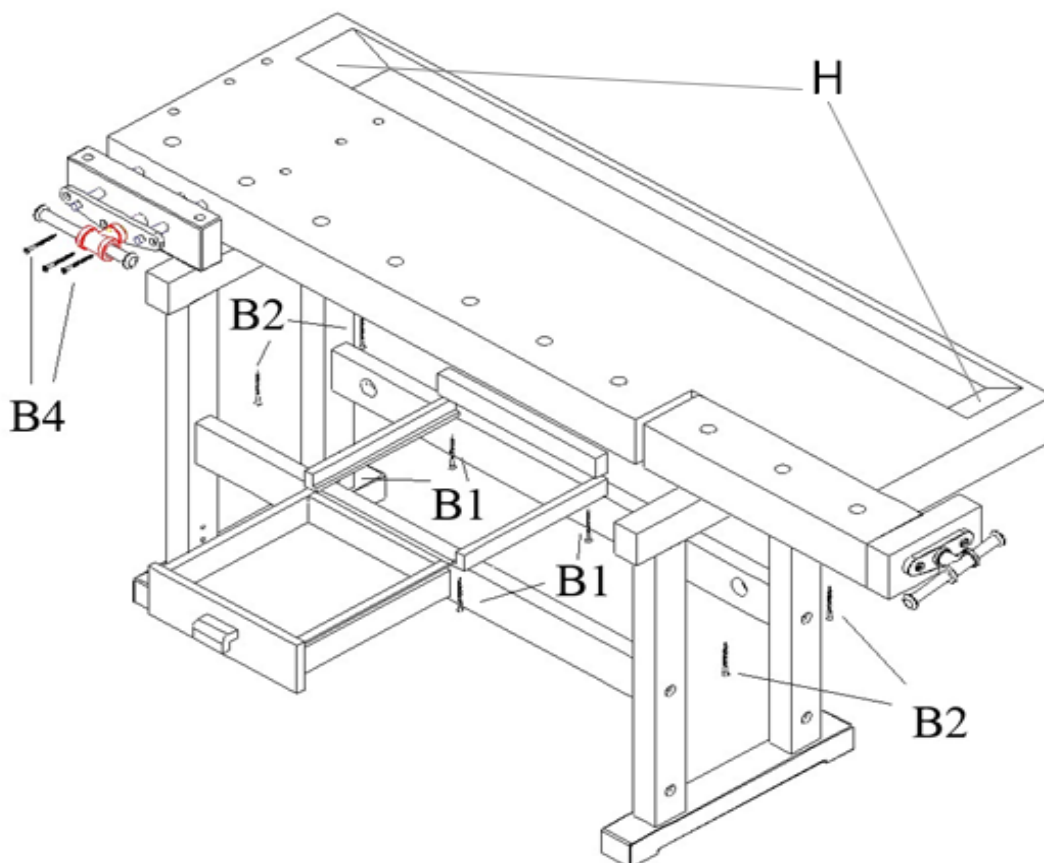

Important! Wedges for tool well are supplied separately (part H). Producer recommends to add wedges after approx. 4 weeks. Workbench needs to adapt to the surrounding conditions. In case of need adjust the size of wedges by size of tool well.